

TRAINING CIRCULAR }
 No. 23-13

HEADQUARTERS
 DEPARTMENT OF THE ARMY
 WASHINGTON, D.C., 20 January 1967

CREW-SERVED WEAPON NIGHT VISION SIGHT

	Paragraph	Page
CHAPTER 1. INTRODUCTION		
Section I. General.....	1-3	1
II. Description and data.....	4-5	1
CHAPTER 2. MECHANICAL TRAINING		
Section I. Introduction.....	6-7	5
II. Disassembly and assembly.....	8-10	5
III. Controls.....	11-12	7
IV. Reticle projector assembly.....	13-14	7
V. Functioning.....	15-16	10
CHAPTER 3. INSTALLATION, OPERATION, AND BORESIGHTING		
Section I. Installation of separately packed components.....	17-20	11
II. Operation of equipment.....	21-24	14
III. Boresighting procedures.....	25-27	17
CHAPTER 4. MAINTENANCE		
Section I. Preventive maintenance.....	28-30	19
II. Troubleshooting.....	31-36	20
CHAPTER 5. TECHNIQUE OF FIRE		
Section I. Range determination.....	37-41	22
II. Fire control.....	42-43	22
CHAPTER 6. MARKSMANSHIP TRAINING		
Section I. Introduction.....	44-45	28
II. Preparatory marksmanship.....	46-47	28
III. Safety precautions, range and firing procedures.....	48-49	33
CHAPTER 7. MARKSMANSHIP		
Section I. Operator's course, crew-served weapon night vision sight mounted on the 106-mm recoilless rifle.....	50-52	39
II. Operator's course, crew-served weapon night vision sight mounted on the caliber .50 machinegun.....	53-55	42
CHAPTER 8. FACTORS AFFECTING EMPLOYMENT.....	56-61	46
APPENDIX A. REFERENCES.....		48
B. ADVICE TO INSTRUCTORS.....		49
INDEX.....		50

CHAPTER 1

INTRODUCTION

Section I. GENERAL

1. Purpose. This training circular provides guidance for the conduct of training with the Crew-Served Weapon Night Vision Sight.

2. Scope. This circular contains a complete description of the Crew-Served Weapon Night Vision Sight, mechanical training to include assembly, disassembly, operation, installation, functioning, and maintenance; marksmanship training to include boresighting, aiming, positions, and zeroing; and other information pertinent to its employment and the conduct of training. This

material is applicable, without modification, to nuclear and nonnuclear warfare.

3. Responsibilities of Users. Users of this publication are encouraged to submit recommended changes or comments to improve the publication. Comments should be keyed to the specific page, paragraph, and line of text in which the change is recommended. Reasons should be provided for each comment to insure understanding and complete evaluation. Comments should be forwarded direct to the Commandant, United States Army Infantry School, Fort Benning, Ga. 31905.

Section II. DESCRIPTION AND DATA

4. Description. *a. General.* The Crew-Served Weapon Night Vision Sight (hereafter referred to as the Sight) is a battery-powered, electro-optical device for observation and aimed fire of weapons at night. The Sight uses the natural light (moonlight and/or starlight) of the night sky for target illumination. Since the Sight does not project infrared or visible light, it offers freedom from the possibility of enemy detection. The Sight is designed for employment on the Browning machinegun caliber .50 HB M2, and the 106-mm recoilless rifle M40A1.

b. Carrying Case. The carrying case is a metal container (fig 1) designed to carry the Sight, in-line and right angle eye pieces, dusting brush, lens tissue, low temperature adapter, two spare lamps, five batteries, and weapons adapter brackets for the Browning machinegun caliber .50 HB M2 and the 106-mm recoilless rifle M40A1. The case has eight latches, two carrying handles, and a pressure relief valve. Foam rubber liners are provided for protection of the Sight and its components. The carrying case with liners allows the Sight to be

airdropped. TM 11-1090-269-15 and the maintenance forms are located under the foam rubber liners.

c. Sight. The Sight (fig 2) consists of the Sight body, objective lens assembly, reticle projector assembly, eyepiece with rubber eyeshield, image intensifier tube, integral high-voltage power supply, a rotary control switch with wiring, and a boresight assembly. The in-line eyepiece is used with the Browning machinegun caliber .50 HB M2, and the right angle eyepiece is used with the 106-mm recoilless rifle M40A1. A 6.75-volt mercury battery provides the power for integral high-voltage power supply, cant level illumination, and the reticle projector assembly. The rotary control switch has four positions: OFF, CANT LEVEL ILLUMINATION ON, TUBE ON, TUBE ON RETICLE ON. The boresight assembly is attached to the bottom of the Sight body. A boresight cover is provided for protection of the image intensifier tube when the Sight is used during daylight hours.

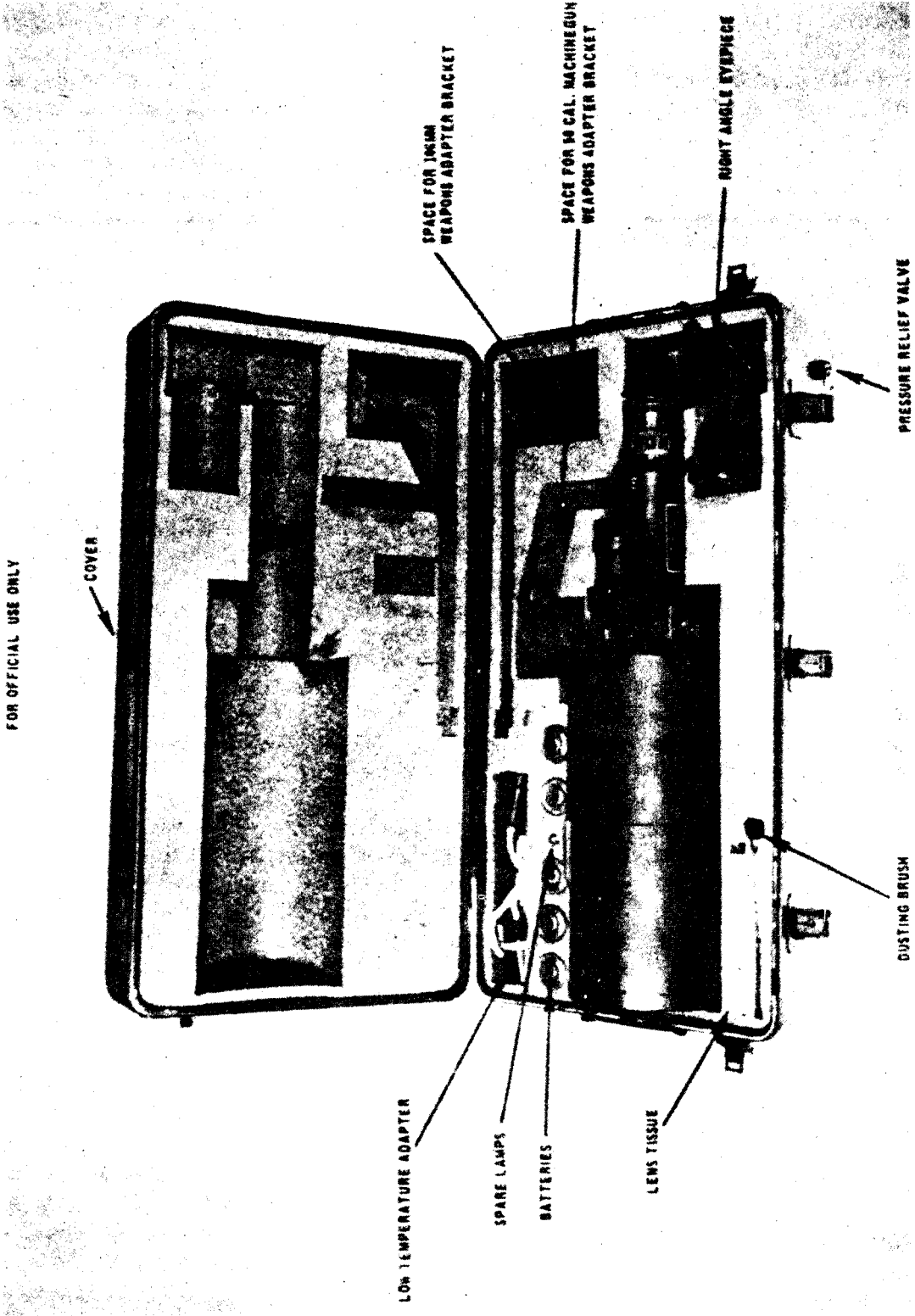

Figure 1. Carrying case with components.

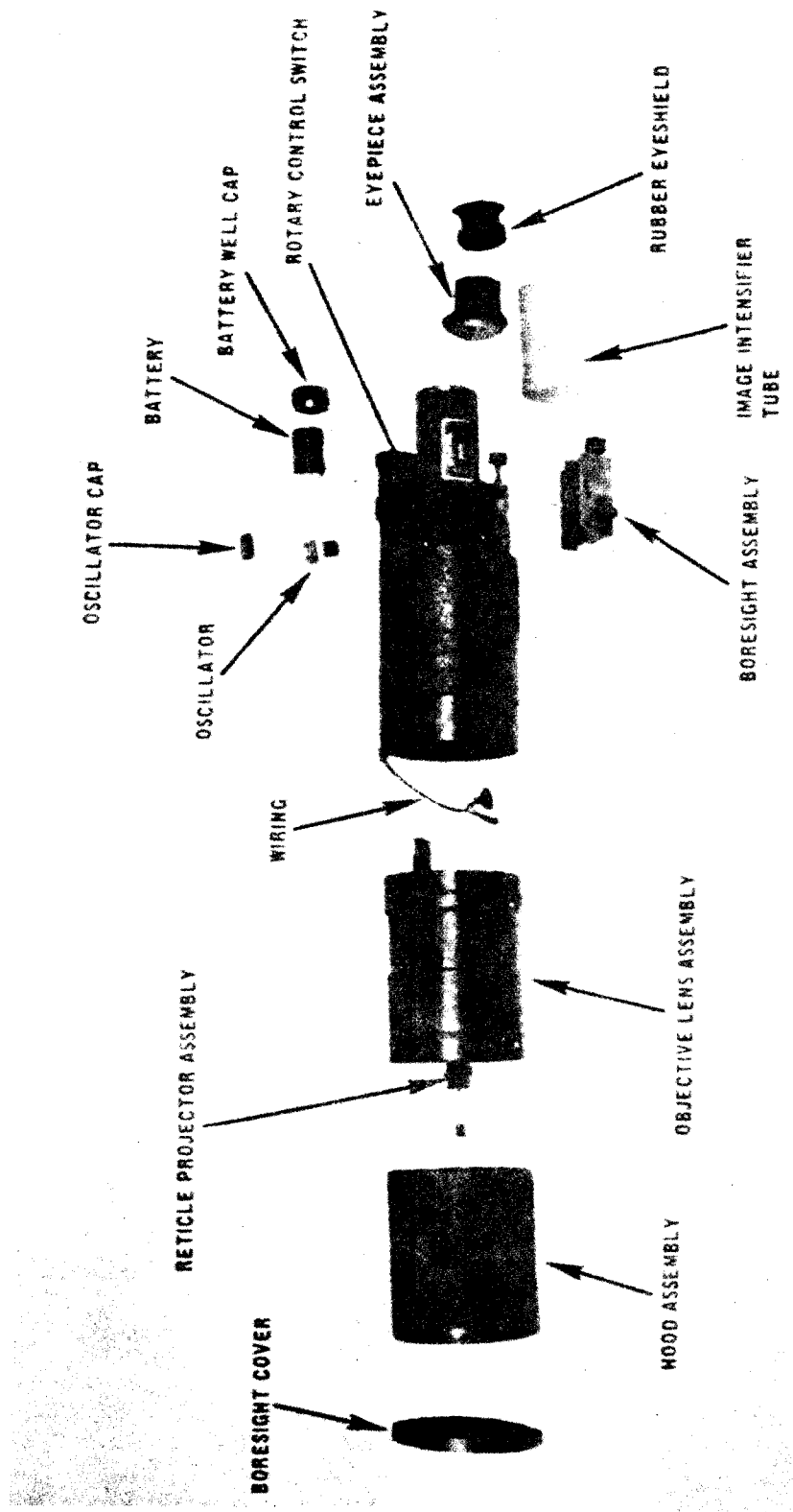

Figure 2. Major components.

5. Tabulated Data. a. Performance.

Normal operating temperature--- 65° to 115° F.
 Magnification----- 7 power.
 Field of view----- 108 mils.
 Eyepiece focus----- +4 to -4 diopters.
 Objective lens focus----- 50 meters to infinity.
 Range----- Dependent on ambient light level (moonlight and/or starlight).

b. Dimensions and Weights.

(1) Carrying case:

Length-----29.25 inch.
 Width----- 15.00 inches.
 Height-----10.50 inches.

Weight with Sight and accessories. 47.50 pounds (approximately).

(2) Sight:

Length----- 24.75 inches
 Width----- 6.31 inches
 Height----- 7.00 inches
 Weight----- 15 pounds

(3) Battery:

Type----- BA 1100 () U Mercury.
 Number of cells----- 5.
 Voltage----- 6.75 volts
 Operational life----- 100 hours (approximately).
 Shelf life----- 2 years under ideal conditions of 70°F.

CHAPTER 2

MECHANICAL TRAINING

Section I. INTRODUCTION

6. General. *a.* The purpose of mechanical training is to give the operator a knowledge of the basic functioning, controls, and adjustable parts of the Sight so that he will understand its operation and be able to properly care for it.

b. The operator is authorized to disassemble the Sight *only* to the extent described in paragraph 8.

c. Even though detailed disassembly is not authorized, this should not preclude teaching the operator the nomenclature of the component parts and accessories.

7. Removal of Sight From Carrying Case.

a. Place the carrying case flat on the ground or a table.

b. To remove the Sight from the carrying case, turn the pressure relief valve two complete turns counterclockwise to release pressure that may have built up in the container. To release the latches, place fingers under the latch and pull up, then remove cover.

c. Remove the Sight and accessories from the container.

d. While operating in damp or wet climates, the cover should be immediately replaced to prevent possible damage to the liners as they readily absorb moisture.

Section II. DISASSEMBLY AND ASSEMBLY

8. General. Operators are allowed to perform field stripping of the Sight for cleaning purposes or replacement of defective parts. No special tools are required to disassemble the Sight. The Sight is waterproofed when manufactured. To retain this condition and to insure proper operation of the Sight, the operator is authorized to remove and replace only the following components:

- a.* Battery.
- b.* Rubber eyeshield.
- c.* Reticule lamp.
- d.* Cant level lamp.

9. Disassembly. *a. Battery (Fig 3).*

- (1) Place switch in OFF position.
- (2) Remove battery cap from the battery housing by turning in a counterclockwise direction (1).
- (3) Remove battery (2).

b. Rubber Eyeshield (Fig 3). The rubber eyeshield (3) is removed by forcefully pulling it from the eyepiece assembly.

c. Reticule Lamp (Fig 3).

CAUTION: The image intensifier tube will be damaged if exposed to the direct rays of the sun, regardless of the position of the rotary control switch. For this reason, remove the boresight cover only under subdued light conditions.

- (1) Remove boresight cover.
- (2) Remove lamp holder (4) by unscrewing cap (5) from reticule projector housing.
- (3) Unscrew lens (6) from lamp holder.
- (4) Remove lamp (7).
- d. Cant Level Lamp (Fig 3).*
 - (1) Remove lamp holder (8) by unscrewing nut (9) from level assembly.
 - (2) Unscrew lens (10) from lamp holder.
 - (3) Remove lamp (11).

10. Assembly. The sequence in which the disassembled parts are assembled is not important; however, during training the operator should use the reverse procedure of disassembly.

a. Position cant level lamp and lens into the

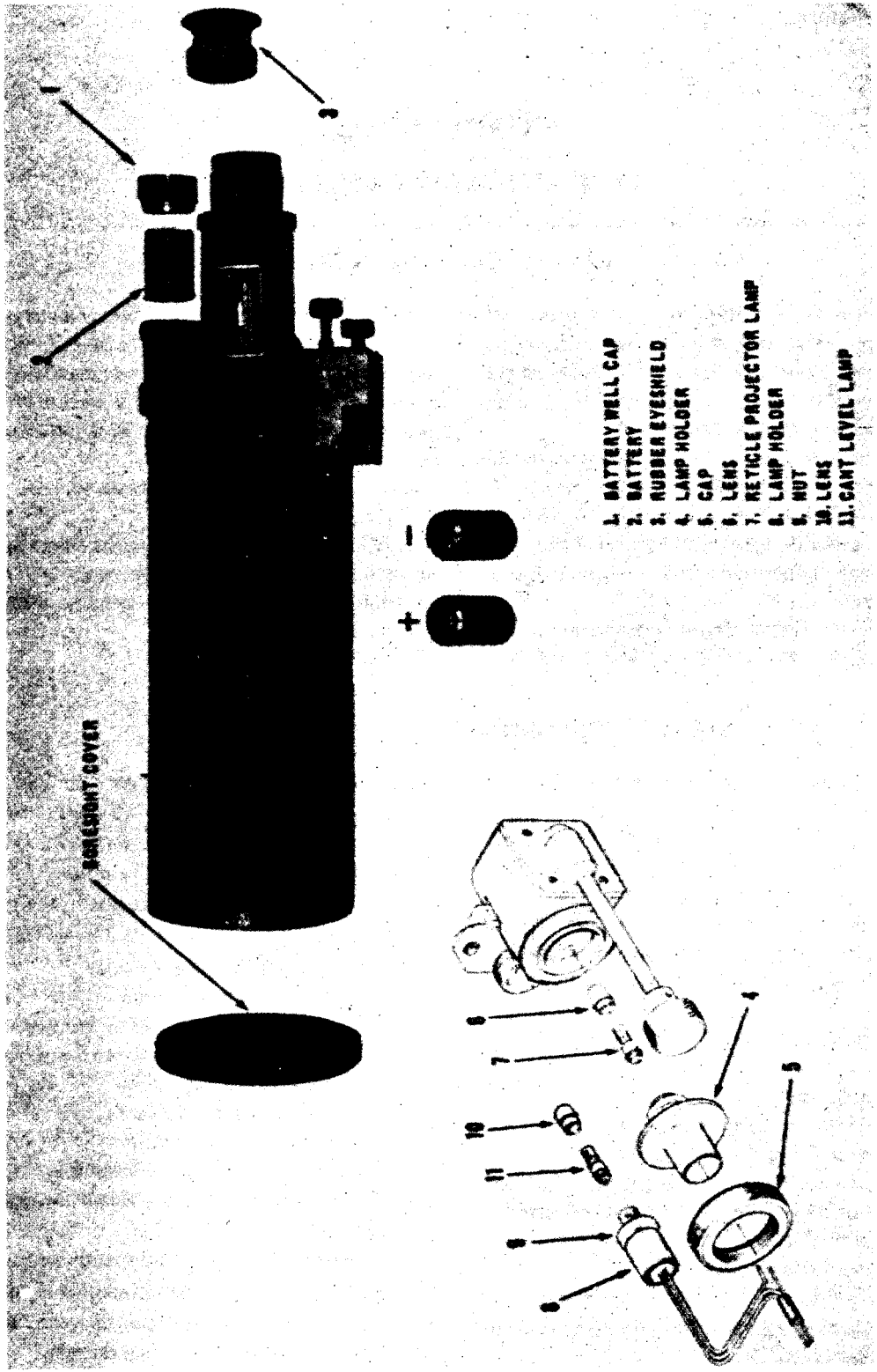

Figure 3. Disassembly.

lamp holder. Secure the lamp holder to the level assembly by tightening the screw.

b. Insert reticle lamp into lamp holder, and screw lens into the latter. Secure lamp holder to the reticle projector housing by tightening the housing cap.

c. Replace the rubber eyeshield and the eyepiece assembly.

d. Insert battery, positive end first, into the battery housing.

e. Replace the battery cap on the battery housing.

Section III. CONTROLS

11. General. Prior to operating the Sight, the operator must become familiar with the controls described in paragraph 12 (fig 4).

12. Controls (Fig 4). *a.* *A Rotary Control Switch (1).* Provides four positions: OFF, CANT LEVEL ILLUMINATION ON, TUBE ON, TUBE ON RETICLE ON.

b. *Reticle Intensity Knob (2).* Allows the operator to increase or decrease the brightness of the reticle under various light conditions. To increase the brightness of the reticle pattern, turn the reticle intensity knob counterclockwise. To decrease brightness, turn the reticle intensity knob clockwise.

c. *Eyepiece Focus Ring (3).* Provides diopter setting from +4 to -4 diopters for individual eye focusing.

d. *Objective Lens Focus Knob (4).* Allows the operator to focus the objective lens for range (distance) from 50 meters to infinity. Objects closer than 50 meters can be seen, but a clear image focus cannot be obtained.

e. *Objective Lens Lock Knob (6).* Allows the operator to lock the objective lens when the correct

focus has been obtained. The lock knob should be used only when firing the weapon to maintain focus. When scanning an area for possible targets, the lock knob must remain loose to prevent stripping of the focusing shift.

f. *Cant Adjustment Knob (6).* Allows the operator to adjust the reticle pattern to insure that it is horizontal regardless of the position of the weapon. This knob moves the reticle pattern *only*; it does not move the Sight body.

g. *Cant Level View Port (7).* Provides an aperture for viewing the cant level vial to insure reticle pattern is horizontal.

h. *Azimuth Adjustment Screw (8).* Adjusts the Sight body, right or left, to boresight the Sight to the weapon. To move the line of aim to the right, rotate the screw counterclockwise.

i. *Elevation Adjustment Screw (9).* Adjusts the Sight body up or down to boresight the Sight to the weapon. To increase range, rotate the screw clockwise. To decrease range, rotate the screw counterclockwise.

j. *Boresight Assembly Lock Knob (10).* Locks the Sight to the Sight mounting bracket. Rotate the knob clockwise to lock the Sight in place.

Section IV. RETICLE PROJECTOR ASSEMBLY

13. General. The reticle projector assembly is located on the front center portion of the objective lens assembly. It consists of the reticle, cant level vial, and the cant adjustment knob.

14. Reticle Pattern (Fig 5). The reticle pattern is a multiple reticle designed for use with the Browning machinegun caliber .50 HB M2, and the 106-mm recoilless rifle. The top center dot is the boresight dot for both weapons. The seven dots

down the center are in 200-meter increments from 0 to 1200 meters, and are used with the caliber .50 machinegun. The six dots on each side and the three dots at the bottom are also divided into 200-meter increments from 0 to 1600 meters and are used with the 106-mm recoilless rifle. The Sight provides 5 mils lead right or left of center as shown in figure 5.

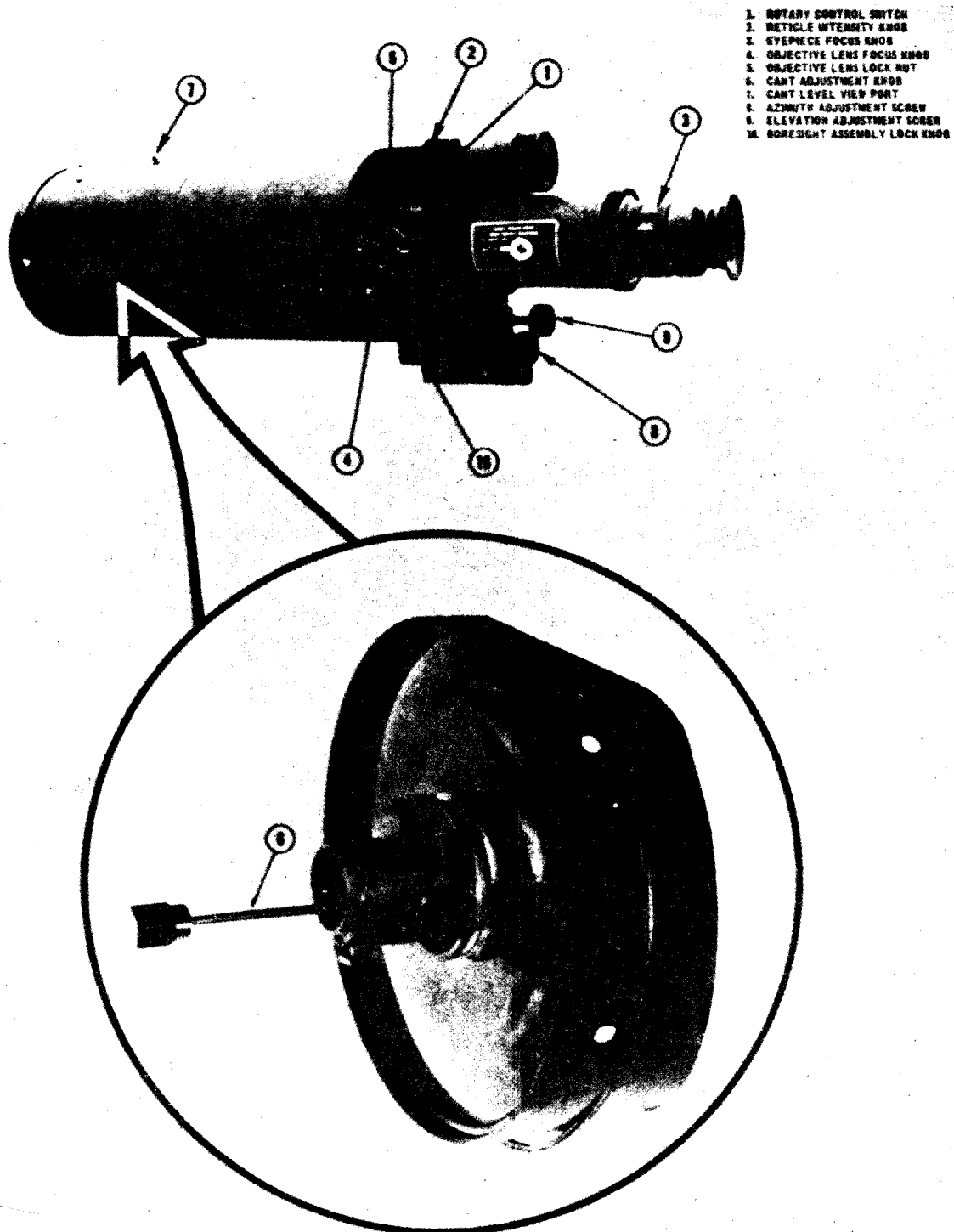

Figure 4. Sight controls.

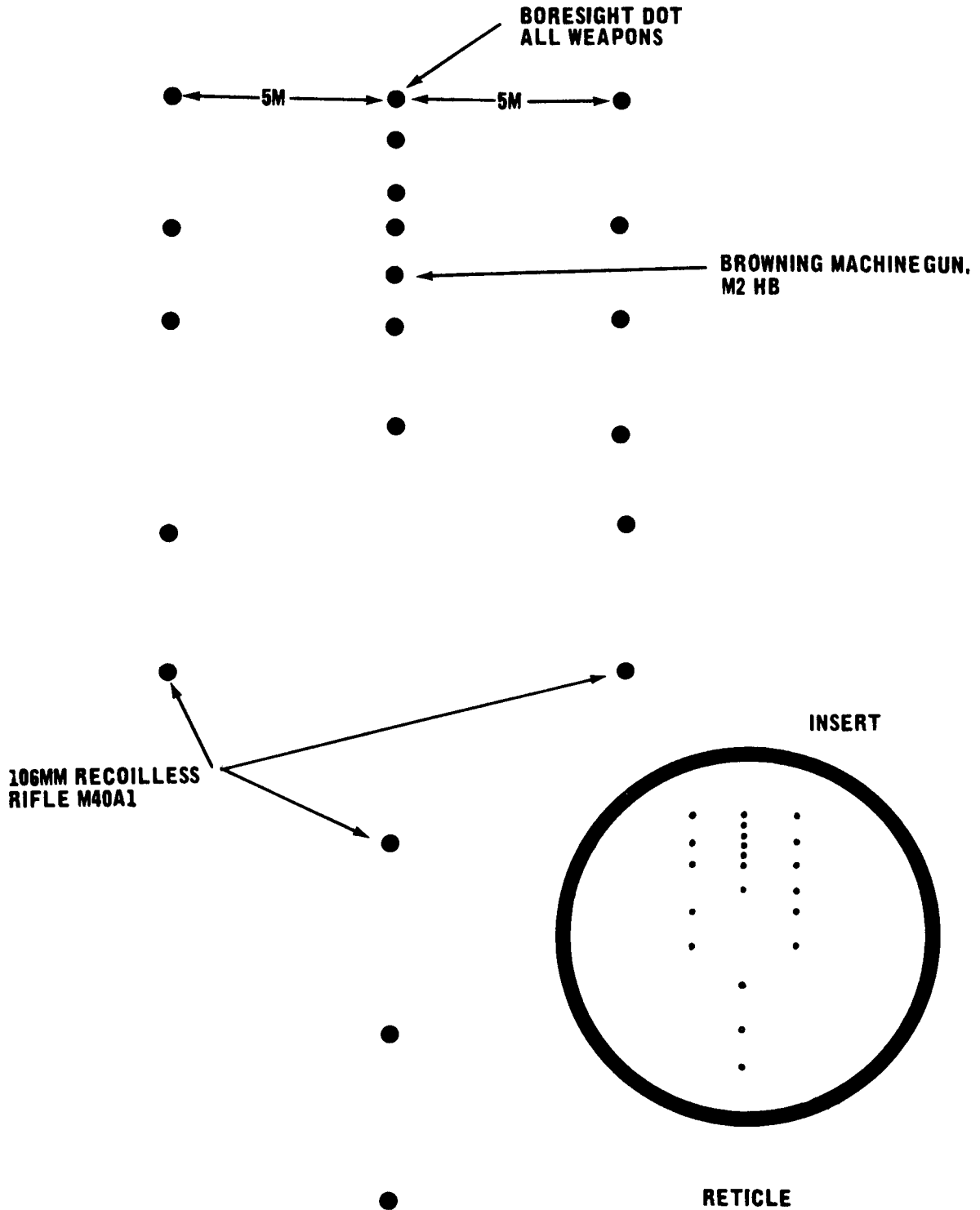

Figure 5. Reticle pattern.

Section V. FUNCTIONING

15. General. For simplification and to prevent discussion of classified material, only the basic functioning of the Sight is described in this section.

16. Functioning (Fig 2). *a. Power Supply.* When the rotary control switch is moved to the third or fourth position (TUBE ON, TUBE ON RETICLE ON) the 6.75-volt battery furnishes the power to the oscillator. The oscillator receives this voltage and increases it from 6.75 volts to 2,800 volts. The increased voltage is transmitted to the multiplier plate on the image intensifier tube. The multiplier plate insures that each stage of the three-stage image intensifier tube receives the required voltage for operation.

b. Objective Lens Assembly. The objective lens assembly, utilizing the available light of the night sky, focuses an image of the target being viewed onto the front face (cathode) of the image intensifier tube. The amount of light at night is at a very low level, and the target is very dim and not visible to the naked eye.

c. Image Intensifier Tube. The image intensifier tube receives the dim image and transmits it to the screen (anode) at the rear of the tube. This amplifies the brightness of the image, so that it may be viewed with the naked eye.

d. Eyepiece Assembly. The eyepiece magnifies and focuses the image of the target which appears on the screen (anode) at the rear of the tube and permits the operator to view it.

CHAPTER 3

INSTALLATION, OPERATION, AND BORESIGHTING

Section I. INSTALLATION OF SEPARATELY PACKED COMPONENTS

17. Right Angle Eyepiece and Low Temperature Adapter. *a. Right Angle Eyepiece.* Direct support maintenance will install the right angle eyepiece when the Sight is used with the 106-mm recoilless rifle. Changing of eyepieces by personnel other than direct support is not authorized.

b. Low Temperature Adapter. If the temperature drops below -20° F., install the low temperature adapter in the following manner (fig 6):

- (1) Turn the rotary control switch (1) to the OFF position.
- (2) Unscrew the battery cap (2) and remove the battery.
- (3) Insert spacer (3) of the low temperature adapter into the battery housing and screw into place.
- (4) Place the battery (4) into the adapter battery case (5), positive end toward wiring as shown in figure 6. Screw the battery cap (2) to the adapter battery case (5).
- (5) Insert the adapter battery case into a pocket to keep the battery warm.

Note. Some models do not contain a low temperature adapter assembly.

18. Installation of Weapons Adapter Bracket and Sight on Browning Machinegun Caliber .50 HB M2 (Figs 7 and 8). The weapons adapter bracket and the Sight are mounted on the caliber .50 machinegun as follows:

- a.* Clear the weapon and raise the cover.
- b.* Loosen the four wingnuts and the four thumbscrews on the weapons adapter bracket. Insure that the screws clear the bottom of the bracket.
- c.* Slide the bracket onto the receiver group with the cutaway portion toward the rear sight of the

machinegun. Check to insure the front of the bracket clears the receiver so the cover will close.

d. Tighten the four thumbscrews securely (if possible, with pliers or other appropriate tool to prevent slipping during firing); then tighten the four wingnuts to lock the bracket in place.

e. Loosen the boresight locking knob by turning the knob counterclockwise. Slide the dovetail notch onto the Sight mounting bracket from rear to front. Secure the boresight locking knob by rotating it clockwise.

19. Installation of Weapons Adapter Bracket and Sight on 106-MM Recoil less Rifle M40A1 (Figs 9 through 11). The weapons adapter bracket and the Sight are mounted on the 106-mm recoilless rifle as follows:

- a.* Clear the weapons system.
- b.* Insure the right angle eyepiece is installed.
- c.* Loosen the two wingnuts on the primary clamp of the weapons adapter bracket.
- d.* Place the weapons adapter bracket primary clamp on the rifle tube, insuring the sleeved pins of the clamp are all the way into the slot of the front spotting gun bracket.
- e.* Wrap the secondary clamp around the, rifle tube and slip the two eyebolts of the primary clamp into the slots of the second clamp. Tighten the wingnuts to secure.
- f.* If the Sight mounting bracket is received separately from the weapons adapter bracket, install as follows: attach the Sight mounting bracket to the weapons adapter bracket with the four washers, lock washers, and cap screws. Once the Sight mounting bracket is installed, do not remove it.
- g.* Loosen the boresight locking knob by turning it counterclockwise. Slide the dovetail notch

- 1. ROTARY CONTROL SWITCH
- 2. BATTERY WELL CAP
- 3. SPACER
- 4. BATTERY
- 5. ADAPTER BATTERY CASE

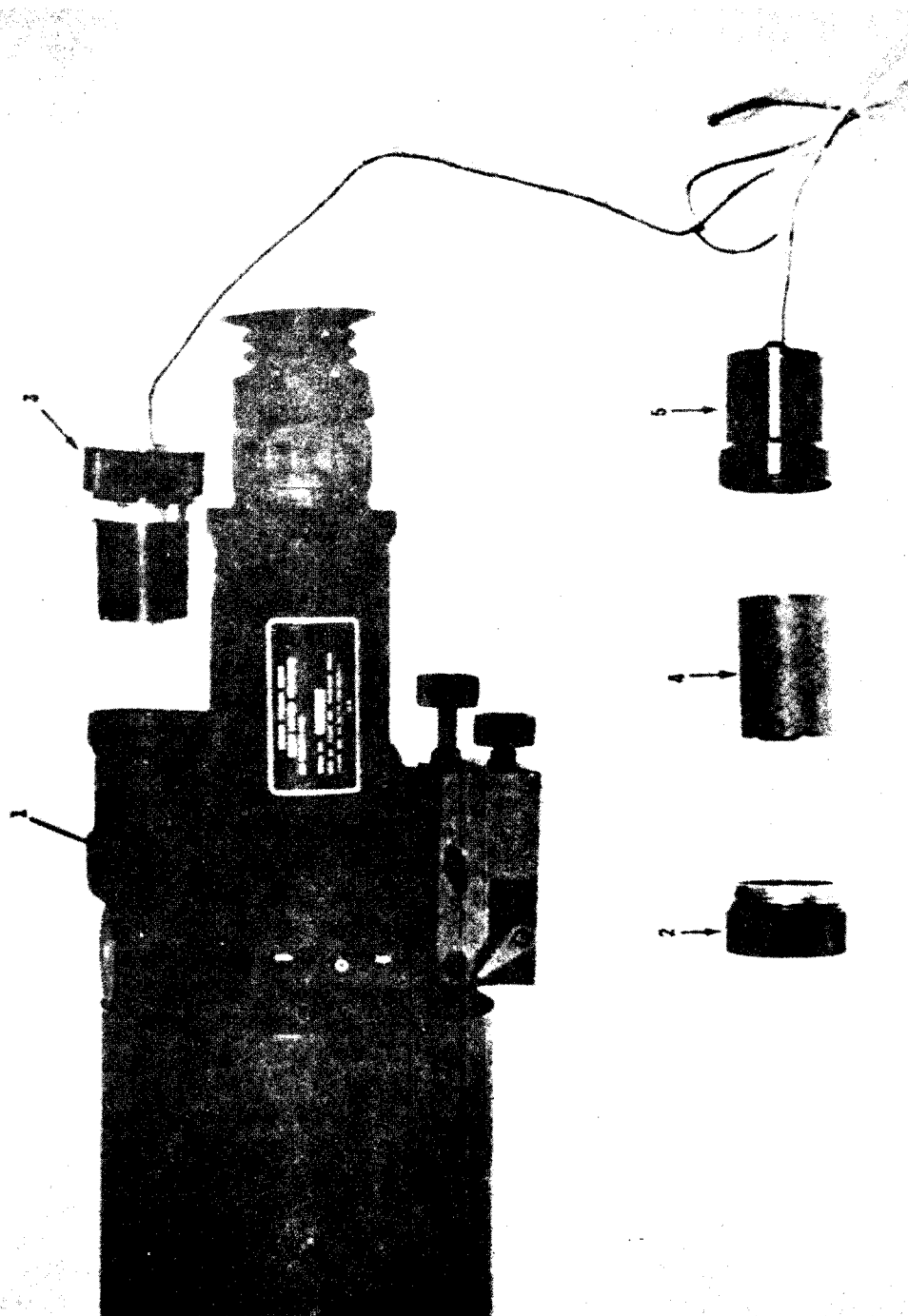

Figure 6. Low temperature adapter installation.

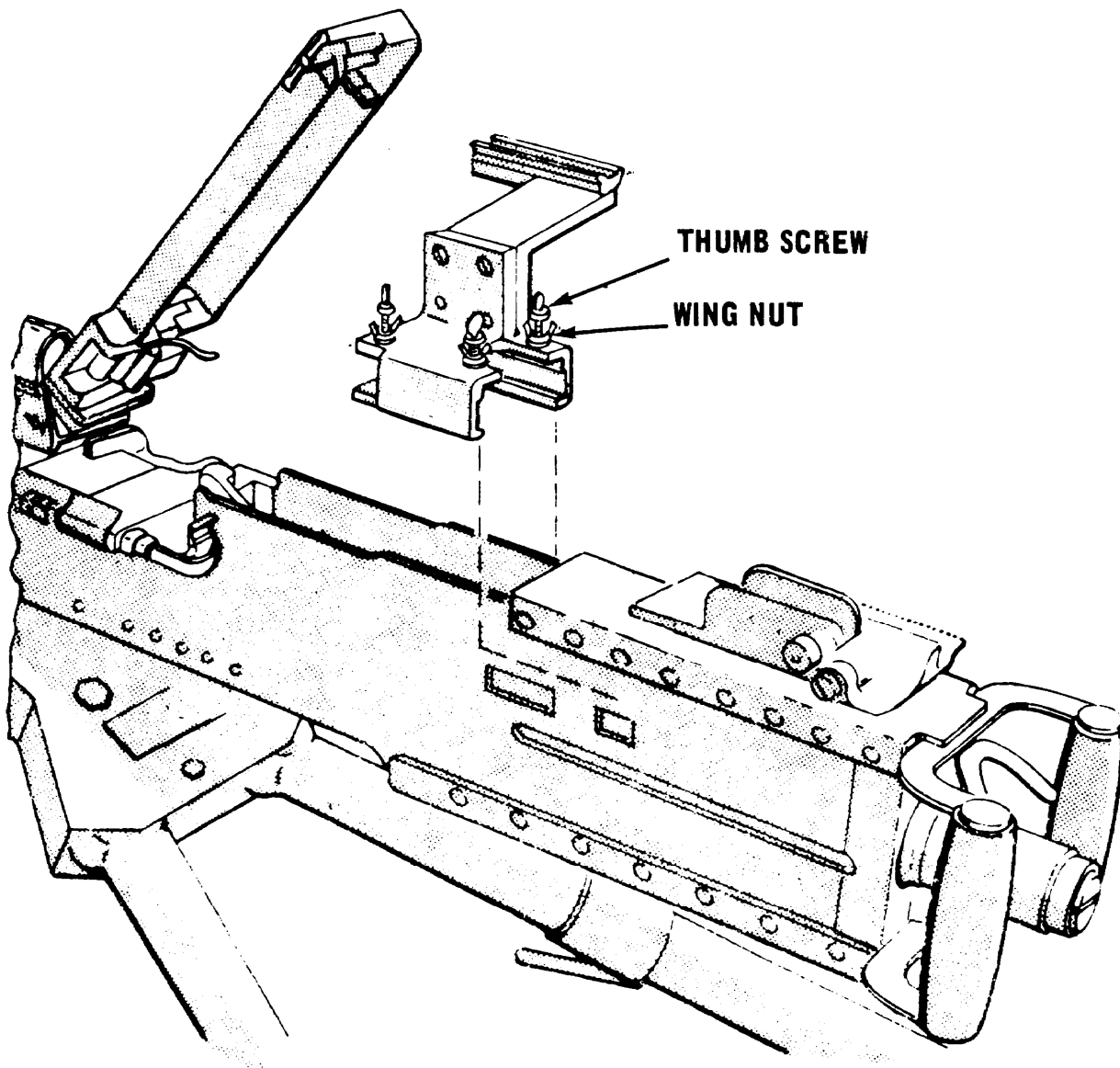

Figure 7. Weapons adapter installation on the caliber .50 machinegun.

of the boresight assembly onto the Sight mounting bracket from front to rear. Secure the boresight locking knob by turning it clockwise.

20. Installation of the Battery. *a.* Insure rotary control switch is in OFF (all the way forward) position.

b. Remove battery cap as described in paragraph 9.

c. Insert battery, positive end first, into the battery housing. To identify the positive end, note the (+) or (-) markings on opposite ends of the battery. Should it be necessary to install a battery during the hours of darkness, the positive end can readily be identified by feeling for the "raised portion" located on the positive end of the battery.

d. Replace the battery cap.

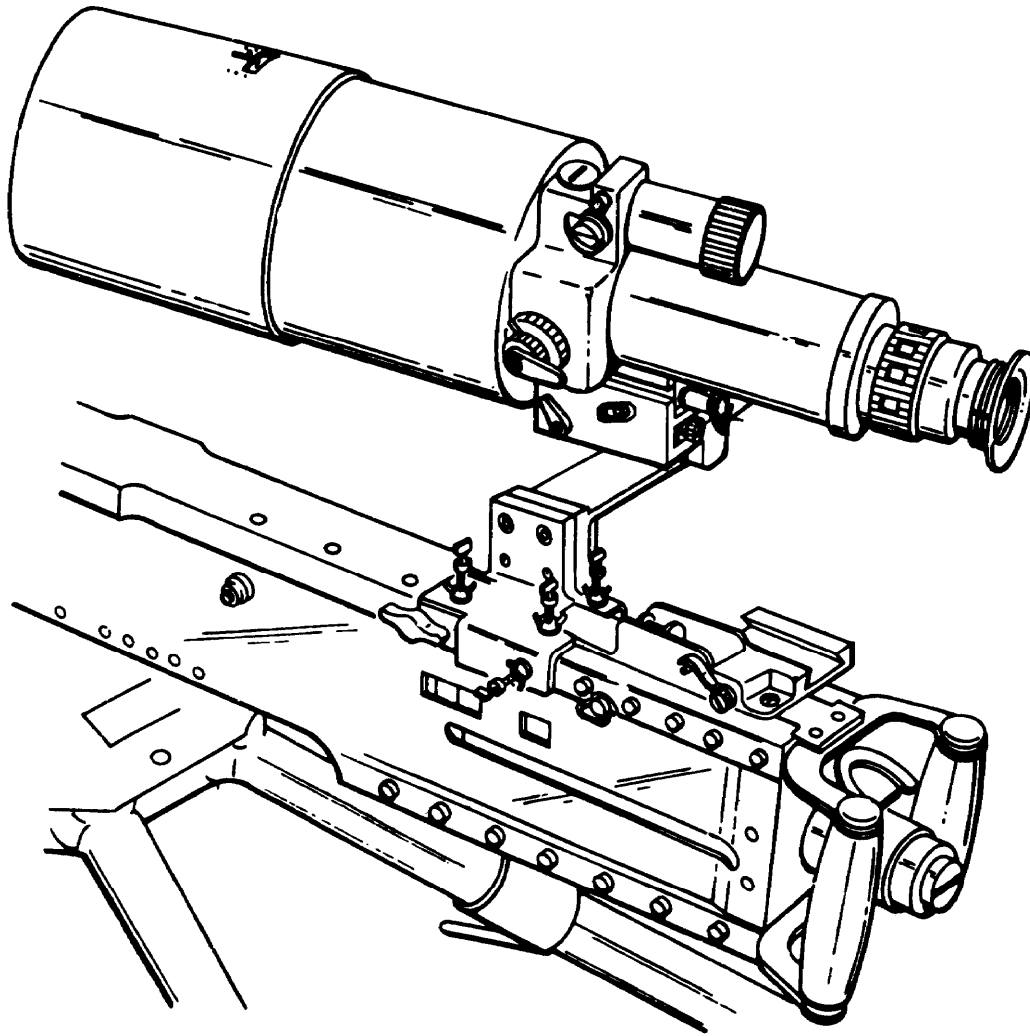

Figure 8. Sight installation on the caliber .50 machinegun.

Section II. OPERATION OF EQUIPMENT

21. General. To prevent damage and to insure proper operation of the Sight, the operator must be able to properly perform all functions necessary to operate the equipment.

22. Operation Under Normal Conditions. *a.* Install the weapons adapter bracket and the Sight on the weapon as outlined in paragraphs 18 and 19.

b. Install the battery as described in paragraph 20.

c. Move the rotary control switch to the first Stop position (CANT ILLUMINATION ON) and open the cant level view port. Adjust the cant adjustment knob (fig 4) until the cant level

vial bubble is centered. The cant adjustment insures that the reticle is horizontal.

d. Turn the rotary control switch to the fourth stop position (RETICLE ON TUBE ON).

e. Adjust the reticle intensity knob until the reticle pattern is visible.

f. Look through the eyepiece with the eye focused only on the reticle pattern. Adjust the eyepiece focus ring so that reticle dots appear sharp and clear. To reduce eyestrain during prolonged usage, back the eyepiece focus ring off slightly toward the zero index.

g. Release the objective lens lock knob by turning it counterclockwise.

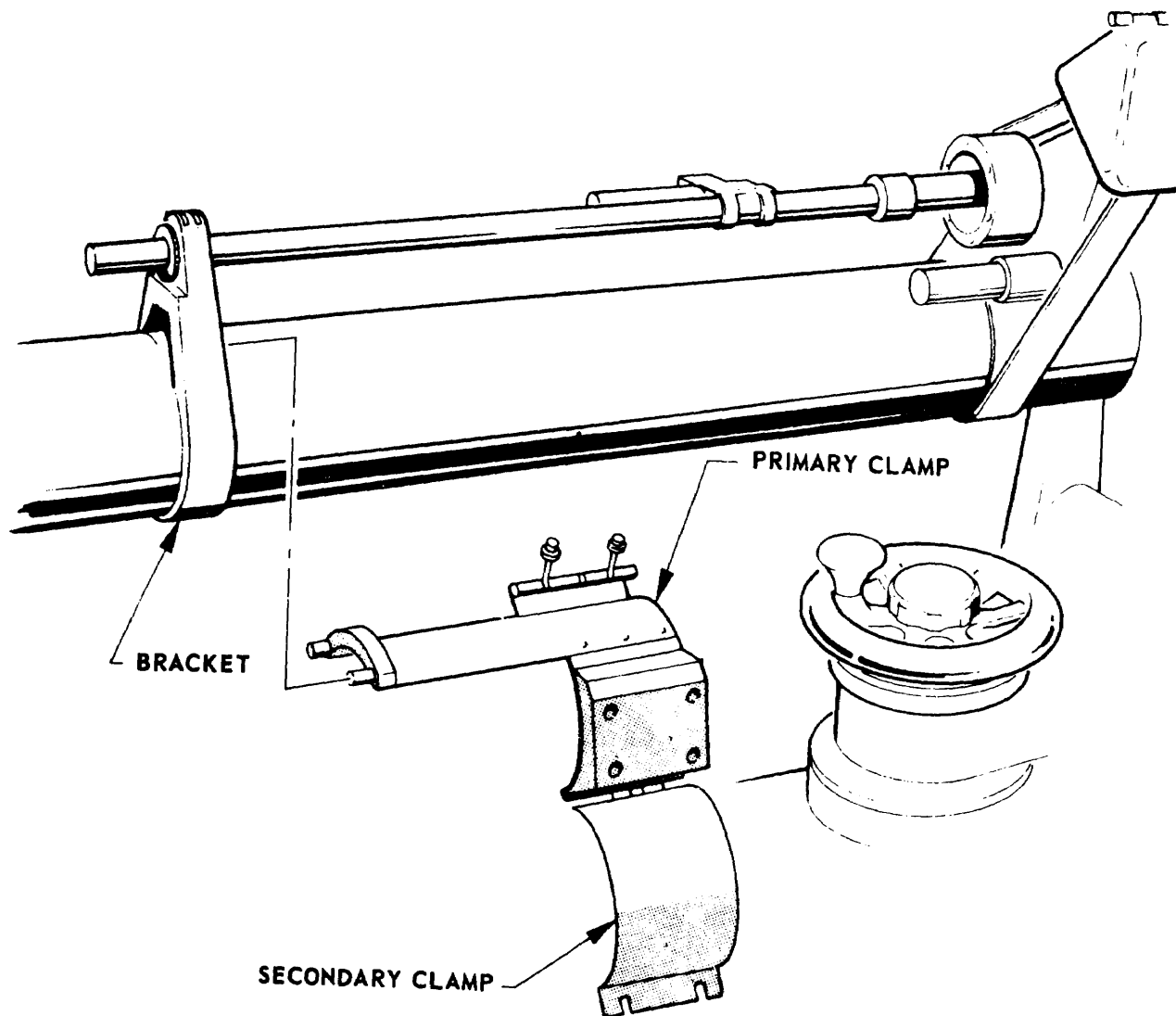

Figure 9. Weapons adapter bracket installation on the 106-mm recoilless rifle.

h. Focus the objective lens on the desired target by rotating the objective lens focus knob.

i. Lock the objective lens lock knob, taking care not to disturb the focus knob setting.

Note. When operating the Sight at night, care must be taken to insure the eye is held firmly against the rubber eyeshield to prevent light leakage. This light may be reflected on the gunner's face and is visible for several meters. After operation, turn the rotary control switch to the OFF position and hold the eye to the rubber eyeshield until the light has diminished.

23. Operation Under Unusual Conditions. *a. Extreme Cold.* The power output of the mercury

battery is greatly reduced in extremely cold temperatures. If the temperature drops below -20° F., the low temperature adapter must be installed as explained in paragraph 17*b*. This allows the operator to place the battery in his clothing for warmth. After the low temperature adapter has been installed, the Sight is operated as under normal conditions. The lenses may have a tendency to fog or frost in cold weather and will require frequent clearing. The operator should avoid breathing into the rubber eyeshield as this will increase fogging and frosting of the eyelens.

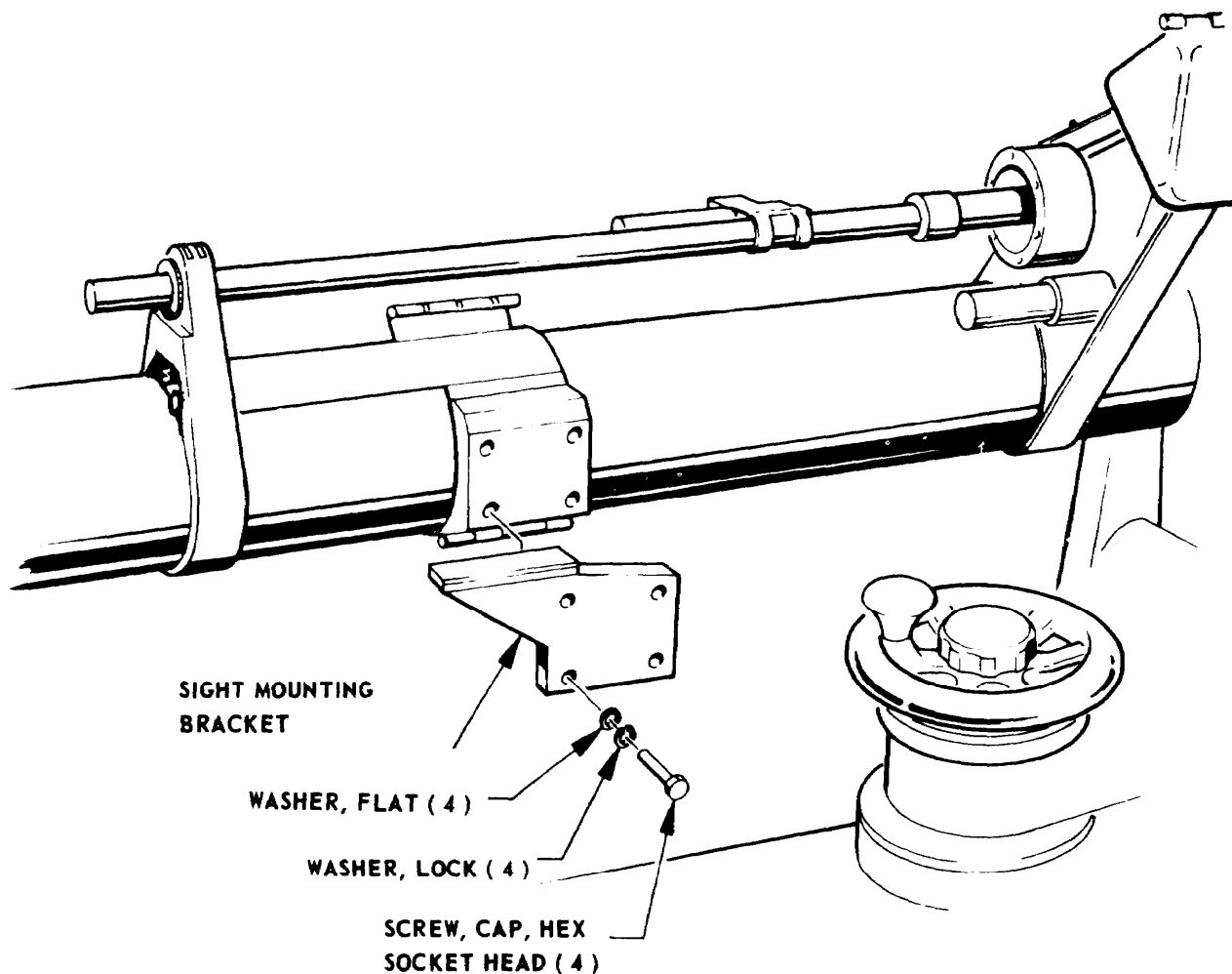

Figure 10. Installation of Sight mounting bracket to weapons adapter bracket (106-mm).

b. Operation in Extreme Heat. The Sight is designed for satisfactory operation at temperatures up to 115° F.

c. Operation in Dusty or Sandy Conditions. The lenses will require frequent cleaning when used during these conditions. To prevent scratching of the lenses, remove most of the accumulated dust and sand with the lens cleaning brush. Then use the lens tissue provided or a soft lint-free cloth for thorough cleaning of the lenses. When the Sight is not in operation, install the boresight cover to prevent damage to the objective lens.

d. Operation in Rainy or Humid Conditions. The Sight is completely waterproof and will perform satisfactorily under these conditions.

24. Displacement of Weapons. *a. Browning Machinegun Caliber .60 HB M2.*

- (1) If the weapon is to be hand-carried for a considerable distance, remove the Sight and the weapons adapter bracket.
- (2) When it becomes necessary to move a considerable distance with the weapon mounted on the M113 armored personnel carrier, the Sight *only* need be removed.

b. 106-mm Recoilless Rifle M40A1. To move a considerable distance with the 106-mm recoilless rifle, remove only the Sight.

Note. When the Sight or any of its components are removed from the weapon, they must be placed in the carrying case to prevent loss or damage.

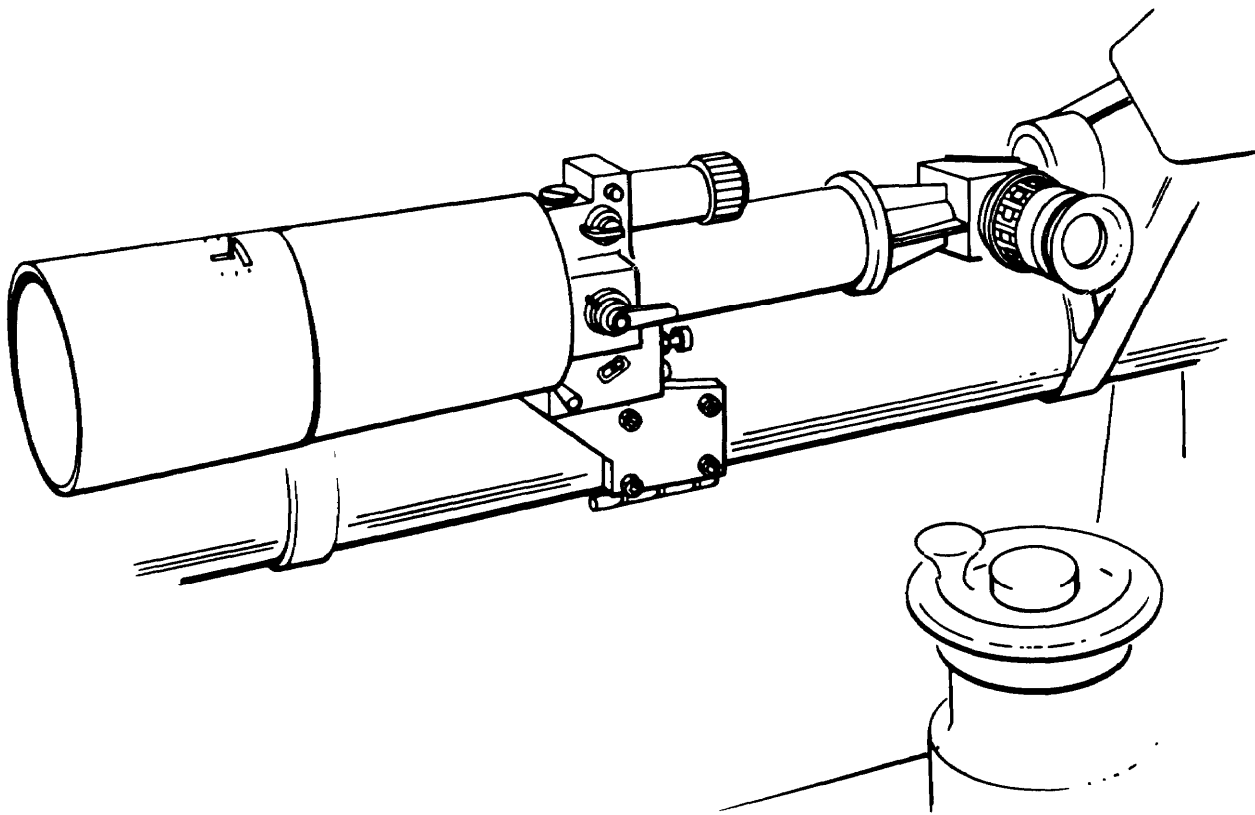

Figure 11. Installation of Sight (106-mm).

Section III. BORESIGHTING PROCEDURES

25. General. To obtain accuracy with a weapon on which the Sight is mounted, the Sight must be boresighted to the weapon. Therefore, the gunner must be thoroughly familiar with the procedures outlined in paragraphs 26 and 27.

26. Procedures for Boresighting in Daylight Hours. *a. Browning Machinegun Caliber .50 HB M2, on the Tripod Mount.*

- (1) Clear the weapon and remove the backplate, driving spring assembly, and bolt group.
- (2) Mount the Sight on the weapon as outlined in paragraph 18.
- (3) Select a distant aiming point beyond the range of a likely target. With the head held to the rear of the receiver, sight through the barrel and align it on the distant aiming point by moving the traversing and elevating mechanism of the gun. A field expedient method may be used to increase the accuracy of align-

ment. To use this method, cut a piece of cardboard that will fit in the rear of the receiver after the backplate has been removed. Place a small pinhole in the cardboard, so that it is centered on the axis of the bore. Place two thin strings or threads across the muzzle with tape, one string horizontal and the other vertical, insuring that the strings cross at the center of the muzzle. By sighting through the pinhole and aligning the crosshairs on the distant aiming point, a more accurate alignment is obtained. After the barrel is aligned on a distant aiming point and without disturbing the lay of the gun, check the cant level vial on the Sight to insure that the bubble is centered; if not, center it by moving the cant adjustment knob.

- (4) With the rotary control switch in the fourth stop position (TUBE ON RETI-

CLE ON) and the *boresight cover installed*, aline the boresight dot of the Sight reticle on the same distant aiming point, by rotating the azimuth and elevation screws on the Sight.

- (5) Recheck the alinement of the bore and the Sight. If the bore and the Sight are laid on the same distant point, correct boresighting has been achieved. If not, repeat (3) and (4) above.
 - (6) For weapons mounted on the M113 armored personnel carrier, use the tripod on the carrier and boresight as outlined above. Once the weapon and Sight are boresighted, they may be mounted on the vehicle's machinegun mount.
- b. 106-mm Recoilless Rifle.*
- (1) Clear the weapons system.
 - (2) Mount the Sight as outlined in paragraph 19.
 - (3) Select an aiming point beyond the range of 2,200 yards (2,000 meters). Aline the axis of the bore and the boresight cross of the M92D sight on the distant aiming point as outlined in FM 23-82.
 - (4) Without disturbing the lay of the weapon, open the cant level view port and check to insure that the bubble is centered. If the bubble is not centered, center it with the cant adjustment knob.
 - (5) Insure the boresight cover is in place and turn the rotary control switch to the fourth stop position (TUBE ON RETICLE ON). Aline the boresight dot of the reticle with the same distant aiming point by rotating the azimuth and elevation screws on the boresight assembly.
 - (6) Recheck the alinement of the bore, the M92D sight, and Crew-Served Weapon Night Vision Sight to insure they are still on the same distant aiming point. When the above conditions have been met, the

106-mm recoilless rifle and the Sight are boresighted.

- (7) To zero the caliber .50 spotting gun to the Sight, select a target at a known range of 1,000 meters. Fire the spotting gun with the 1,000-meter dot of the Sight laid on the target. If the spotting round does not hit the target, adjust the spotting gun to bring the spotting round to the center of mass of the target. Make adjustments on the spotting gun by rotating the azimuth and elevation cams on the front mounting bracket. Upon receiving a spotting strike in the center of mass of target, the spotting gun is zeroed, and the weapons system and the Sight are alined.

27. Procedures for Boresighting at Night.

a. General. Boresighting at night should be considered only as an alternate method, since some weapons require partial disassembly, thus putting the gun out of action at a critical time.

b. 106-mm Recoilless Rifle. The procedures at night are the same as those used during daylight, except that the boresight cover is removed and a bright, distinct point, such as a star, is used for the distant aiming point.

c. Caliber .50 Machinegun. Mount the Sight on the machinegun and remove the boresight cover. Select a target at a known distance between 200 and 800 meters. Center the cant level vial of the Sight. Lay the Sight reticle dot corresponding to the range to the target by moving the traversing and elevating mechanism of the gun. Fire a single tracer round and note the strike of the round in relation to the target. Make the necessary corrections on the azimuth and elevation screws of the Sight to bring the strike of the round into the center mass of the target. Re-lay the gun and fire a confirming round. If the round does not hit the target, continue this process until a target hit is achieved.

CHAPTER 4

MAINTENANCE

Section I. PREVENTIVE MAINTENANCE

28. General. *a.* This section contains only that information needed by the operator to maintain the Sight. Information concerning organizational or higher levels of maintenance are outlined in TM 11-1090-269-15.

b. Daily preventive maintenance must be performed to detect and correct deficiencies before serious damage to, or failure of, the device results.

c. When the equipment is not in use and is stored in the shipping container, it must be cleaned and inspected weekly.

d. All deficiencies and shortcomings, with the corrective action taken, will be recorded on DA Form 2404 (Equipment Inspection and Maintenance Worksheet).

29. Cleaning Materials, Lubricants, Tools, and Equipment. *a. Cleaning Materials.*

- (1) Lens tissue paper is provided in the shipping container for cleaning all glass surfaces. Lens tissue can be requisitioned through normal supply channels; however, a soft lint-free cloth may be used as a substitute.
- (2) The lens brush furnished in the shipping container is used to remove excess dirt, grit, or sand from glass surfaces.
- (3) Alcohol or distilled water should be used with the lens tissue or lint-free cloth to remove grease or other foreign substances from the lenses.
- (4) A damp cloth may be used to remove dirt or mud from the outer surfaces of the Sight body.

b. Lubricants. There are no lubrication requirements for the Sight. The weapons adapter brackets require a light coat of oil on exposed areas to prevent rust. For this purpose PL special or 10W motor oil may be used.

c. Tools and Equipment. The accessories provided in the carrying case are the only tools and equipment required by the operator to perform maintenance on the Sight.

30. Daily Preventive Maintenance. The daily preventive maintenance to be performed by the operator is as follows:

a. Carrying Case.

- (1) Visually inspect the carrying case for dents, holes, cracks, or dirt. Report deficiencies to organizational maintenance. If dirty, clean with a damp cloth.
- (2) Check latches, carrying handles, and pressure relief valve for proper operation. Report deficiencies to organizational maintenance.
- (3) Insure all components are present.
- (4) Remove the Sight and all accessories from the container, and inspect the foam rubber liners for damage. Remove accumulated dust or dirt with a damp cloth. If liners are damp or wet, remove them and allow them to dry. The liners are force-fitted and are not glued or secured with screws. To remove from the container, grasp the liners with the hanck and pull out. To replace the liners, insure that the cutaway portions match, and force them into the container.

b. Components.

- (1) *Weapon adapter brackets.*
 - (a) Inspect for presence, and free operation of, the wingnuts and thumbscrews.
 - (b) Inspect the dovetail for presence of the stop pin. Check the shoulders of dovetail for burs.
 - (c) Report faulty conditions to organizational maintenance.

- (2) *Low temperature adapter.*
- Inspect wiring for cracks or breaks.
 - Install the low temperature adapter as outlined in paragraph 17b, and check for proper operation.
 - Report faulty conditions to organizational maintenance.
- (3) *Batteries.* Inspect for cracks or breaks in the battery bodies. If faulty, dispose of batteries and requisition replacements through normal supply channels.
- CAUTION: Never burn batteries as they will explode and the fumes from the mercury cells are harmful to the eyes, nose, and respiratory system. To dispose of batteries, bury or deposit in a large body of water.**
- c. *Crew-Served Weapon Night Vision Sight.*
- (1) *Sight body.* Inspect for dents, cracks, and dirt. If dirty, clean with damp cloth; if cracked or dented, report faulty condition to organizational maintenance.
 - (2) *Objective lens assembly.* Inspect for scratches, or dirt. If cracked or scratched, report faulty conditions to organizational maintenance. If dirty, clean with alcohol or distilled water and lens tissue or lint-free cloth.
 - (3) *Cant level vial lamp.* Open the cant level view port, turn the rotary control switch to the second stop position, and check for cant level illumination. If no illumination, refer to paragraph 35 for corrective action.
 - (4) *Cant correction knob.* Inspect for free operation and level vial response. Report faulty conditions to organizational maintenance.
 - (5) *Cant level vial.* Check for bubble response and possible damage of vial. Report faulty conditions to organizational maintenance.
 - (6) *Image intensifier tube.* In a darkened area or with the bcmsight. cover in place, turn the rotary control switch to the third stop position and check for tube illumination (reticle should not be on in this position). If there is weak or no illumination, refer to paragraph 33 for corrective action.
 - (7) *Reticle intensity knob.* Turn the rotary control switch to the fourth stop position. Rotate the reticle intensity knob until the reticle pattern is clearly visible. If reticle pattern cannot be seen, refer to paragraph 32 for corrective action.
 - (8) *Objective lens focus knob.* Inspect for free operation and image focusing. If the knob does not operate freely, report faulty operation to organizational maintenance.
 - (9) *Objective lens lock knob.* Check for positive locking action. Report faulty operation to organizational maintenance.
 - (10) *Eyepiece assembly.* Inspect lens for cracks, scratches, or dirt. If dirty, clean with lens brush and/or lens tissue. If greasy, clean with alcohol, distilled water, and lens tissue or soft lint-free cloth. Rotate the eyepiece focusing ring and check for free operation and focusing action. Report faulty operations to organizational maintenance.
 - (11) *Rubber eyeshield.* Inspect for dirt. If dirty, clean with a damp cloth. If rubber is cracked or shows signs of deterioration report condition to organizational maintenance.
 - (12) *Boresight assembly.* Inspect dovetail slot for burs or other flaws. Check lock knob for positive locking action. Inspect azimuth screw for free operation and horizontal movement of Sight body. Check elevation screw for free operation and vertical movement of Sight body. Report faulty operations or conditions to organizational maintenance.

Section II. TROUBLESHOOTING

31. General. This section provides information that is helpful in diagnosing and correcting unsatisfactory operation or failure of the Sight. Each trouble symptom stated is followed by a probable cause and possible remedy.

32. No Illumination of Reticle.

- | <i>Probable cause</i> | <i>Possible remedy</i> |
|------------------------------------|---|
| a. Weak or defective battery _____ | Replace battery (para 9a and 10d). |
| b. Defective reticle lamp _____ | Replace lamp (para 9c and 10b). |
| c. Faulty wiring _____ | Report condition to organizational maintenance. |

33. Weaker No Illumination of Image Intensifier Tube.

- | <i>Probable cause</i> | <i>Possible remedy</i> |
|------------------------------------|---|
| a. Weak or defective battery _____ | Replace battery (para 9a and 10d). |
| b. Weak or defective tube _____ | Report condition to organizational maintenance. |

34. Image Blurred.

- | <i>Probable cause</i> | <i>Possible remedy</i> |
|---|------------------------------------|
| a. Objective lens eyepiece lens dirty or fogged _____ | Clean lens (para 29). |
| b. Objective lens out of focus _____ | Adjust objective lens focus knob. |
| c. Eyepiece out of focus _____ | Adjust eyepiece focus ring. |
| d. Weak battery _____ | Replace battery (para 9a and 10d). |

35. Weak or No Illumination of Cant Level Vial.

- | <i>Probable cause</i> | <i>Possible remedy</i> |
|------------------------------------|---|
| a. Weak or defective battery _____ | Replace battery (para 9a and 10d). |
| b. Defective lamp _____ | Replace lamp (para 9d and 10a). |
| c. Faulty wiring _____ | Report condition to organizational maintenance. |

36. Destruction To Prevent Enemy Use. a.

General.

- (1) Destruction of the Crew-Served Weapon Night Vision Sight and related material when subject to capture or abandonment in the combat zone will be undertaken by the using unit when, in the judgment of the unit commander, such action is necessary in accordance with orders, or policy established by the company commander concerned. If at all possible, the Sight should be evacuated.
- (2) When the commander concerned considers it necessary, he orders the Sight's destruction to prevent one or more of the following:
 - (a) Capture by the enemy.
 - (b) Abandonment in the combat zone.
 - (c) To deprive the enemy intelligence agencies knowledge of its existence, functioning, or exact specifications.

b. Principles of Destruction.

- (1) Destruction should be as complete as possible within the limitations of time and equipment. In any event, the most important parts are destroyed or evacuated. The same essential parts are destroyed or

evacuated on all units to prevent the enemy from constructing one complete Sight from several damaged ones.

- (2) Personnel are trained in the prescribed methods of destruction.
- (3) The issue and use of special equipment, such as incendiary grenades, are command decisions, and depend on the tactical situation.
- (4) Methods described are listed in the order of their effectiveness. Follow the sequence in which the steps are listed.

c. Methods of Destruction.

- (1) *Destruction by burning.* Stand the Sight on end, with the eyepiece assembly up, and remove the rubber eyeshield. Position a thermate grenade on the eyepiece assembly and pull the pin. Insure that the grenade has destroyed the optics and image intensifier tube.
- (2) *Destruction by weapons fire.* Place the Sight on end, with the eyepiece assembly up. Fire one or more rounds into the Sight through the eyepiece assembly. Insure the round(s) penetrates through the eyepiece, image intensifier tube, and the objective lens assembly.

CHAPTER 5

TECHNIQUE OF FIRE

Section I. RANGE DETERMINATION

37. Introduction. Before the Sight can be effectively employed using any firing technique, certain fundamentals must be understood and applied. The procedures outlined in this chapter cover only those portions applicable to the Sight. The technique of fire for the weapons on which the Sight is mounted is prescribed in detail in FM 23-65 and FM 23-82.

38. General. One of the greatest advantages of the Sight is the element of surprise, therefore fast and accurate range determination is extremely important to insure first-round hits. Methods of estimating ranges are:

- a. Map distance.
- b. Determination by eye.
- c. Determination by fire.

39. Map Distance. Accuracy of determining range from a map depends on map reading ability and accuracy of the map. For a detailed explanation of this method refer to FM 21-26. Use of this method with the Sight will require the operator to prepare a range card. Where preparing a range card for use with the Sight, care must be taken to select targets that can be easily detected at night. Objects situated on open and/or high ground are easier to detect with the Sight. For fast and accurate range determination, select reference points at various ranges throughout the weapon's sector of fire. For a detailed explanation of range card construction, refer to the appropriate field manual(s) covering the weapon on which the Sight is mounted.

40. Determination by Eye. The same methods described in FM 23-71 can be used with the Sight at night. However, when using the appearance-of-objects method the gunner must remember the Sight has a 7-power magnification. Because of this magnification, targets will appear closer to the gunner. To determine range accurately when using the Sight, a great deal of night training is required.

41. Determination by Fire. *a. 106-mm Recoilless Rifle.*

- (1) The spotting gun, when properly zeroed, has a trajectory that closely matches the 106-mm recoilless rifle trajectory up to approximately 1,400 meters (1,500 yards).
- (2) Use of the spotting gun is the fastest method of adjustment with the 106-mm recoilless rifle; however, proper use of the methods described in paragraphs 38 and 39 will help to retain the element of surprise. When a spotting round strikes the desired point of impact on target, the 106-mm recoilless rifle is fired immediately.

b. Caliber .60 Machinegun. To use this method with the machinegun, estimate the range to the target and fire a single tracer round. Note the strike of the round and make the necessary corrections to engage the target.

Section II. FIRE CONTROL

42. General. Fire control at night is difficult even under ideal conditions. When using the Sight, the gunner will be able to detect targets that the leader cannot see. Therefore, the leader must

establish a sound standing operating procedure (SOP) for the engagement of targets under these conditions.

43. Adjustment of Fire. Adjustment of fire

is one of the most important phases of fire control. If first-round hits are not achieved, rapid adjustments of fire are made with subsequent rounds. Different methods are used depending upon range, visibility, and type of ammunition fired. The methods for the 106-mm recoilless rifle are: caliber .50 spotting gun, burst-on-target, and observation of tracer. For the caliber .50 machinegun, two methods are used: burst-on-target and observation of tracer. Adjustment of fire for the 106-mm recoilless rifle is described below.

a. Adjustment of Caliber .50 Spotting Gun.

- (1) This is the primary method of fire adjustment with the weapons system up to 1,000 meters (1,200 yards). With a well-trained gunner it is the most accurate and rapid method of fire adjustment. The gunner has complete control over the adjustment of his fire by using the burst-on-target and/or the observation-of-tracer method.
- (2) The gunner fires the spotting gun. He notes the point on the Sight reticle where the burst appears and moves this point into the center mass of the target (fig 12). He again fires the spotting gun. This should give him a target hit. If so, he immediately fires the major caliber.
- (3) In the event the projectile passes over the target, the gunner will use the observation-of-tracer method, the only difference being that if the tracer passes beyond the target, the gunner does not sense the burst. Instead, he senses the point on his reticle where the tracer passed

the target and moves this point on the reticle to the center mass of the target to fire his subsequent round (fig. 13).

b. Burst-on-Target Method. This method may be used when the caliber .50 spotting gun is inoperative or the range is greater than 1,400 meters (1,500 yards) but not more than 2,000 meters (2,200 yards). The gunner estimates the range to the target, and places the range on his reticle. He fires the major caliber. If this round does not hit the target, he notes the point on his Sight reticle in the center of burst before the burst indication disappears. He then moves that exact point to the center mass of the target to fire his subsequent round. Should the gunner fail to achieve a hit with his second round, he repeats this process, moving the new center of burst to the center of the target.

c. Adjustment by Observation of Tracer.

- (1) 106-mm recoilless rifle. When the gunner is using HEP-T ammunition, he employs the tracer-on-target method of fire adjustment. This method is essentially the same as the burst-on-target method, the only difference being that if the tracer passes beyond the target, the gunner does not sense the burst. Instead, he senses the point on his reticle where the tracer passed the target and moves this point on the reticle to the center mass of the target to fire his subsequent round.
- (2) *Adjustment of fire, caliber .50 machinegun.* The same methods used with the 106-mm recoilless rifle spotting gun are used with the caliber .50 machinegun.

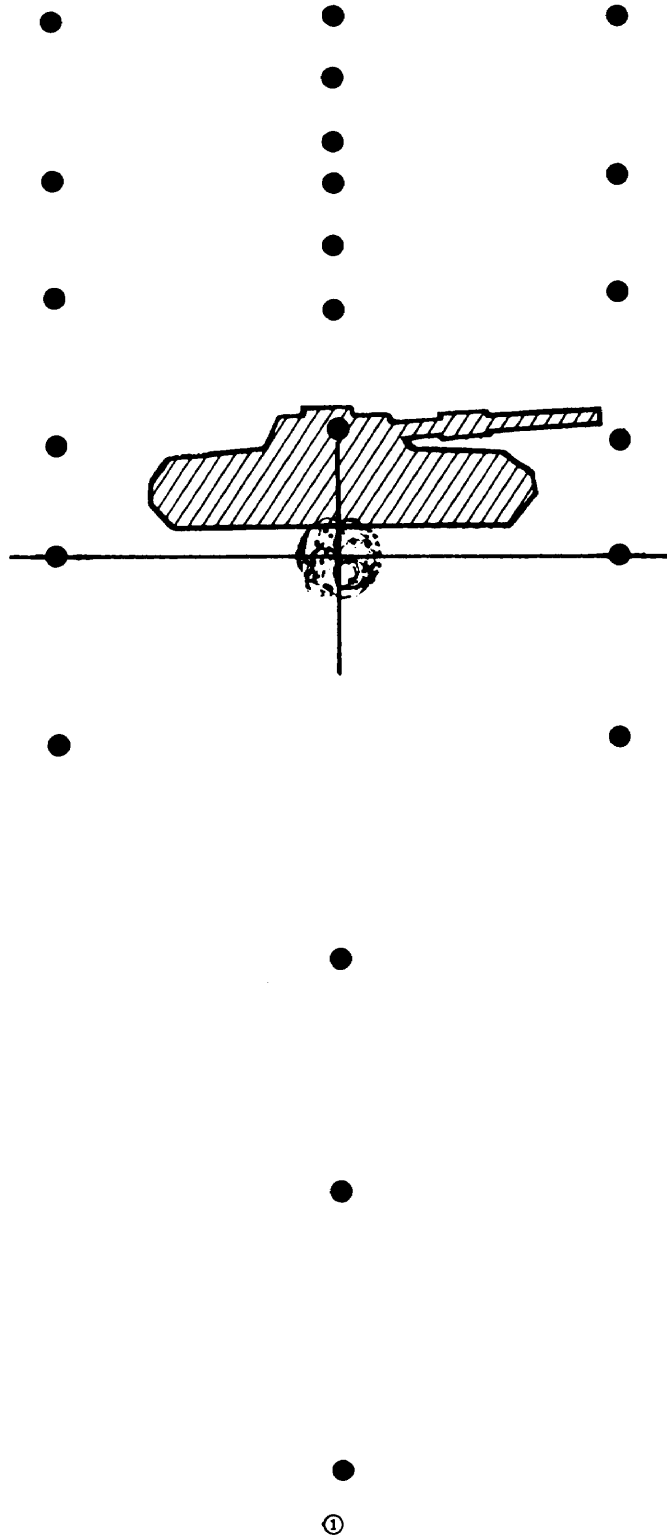
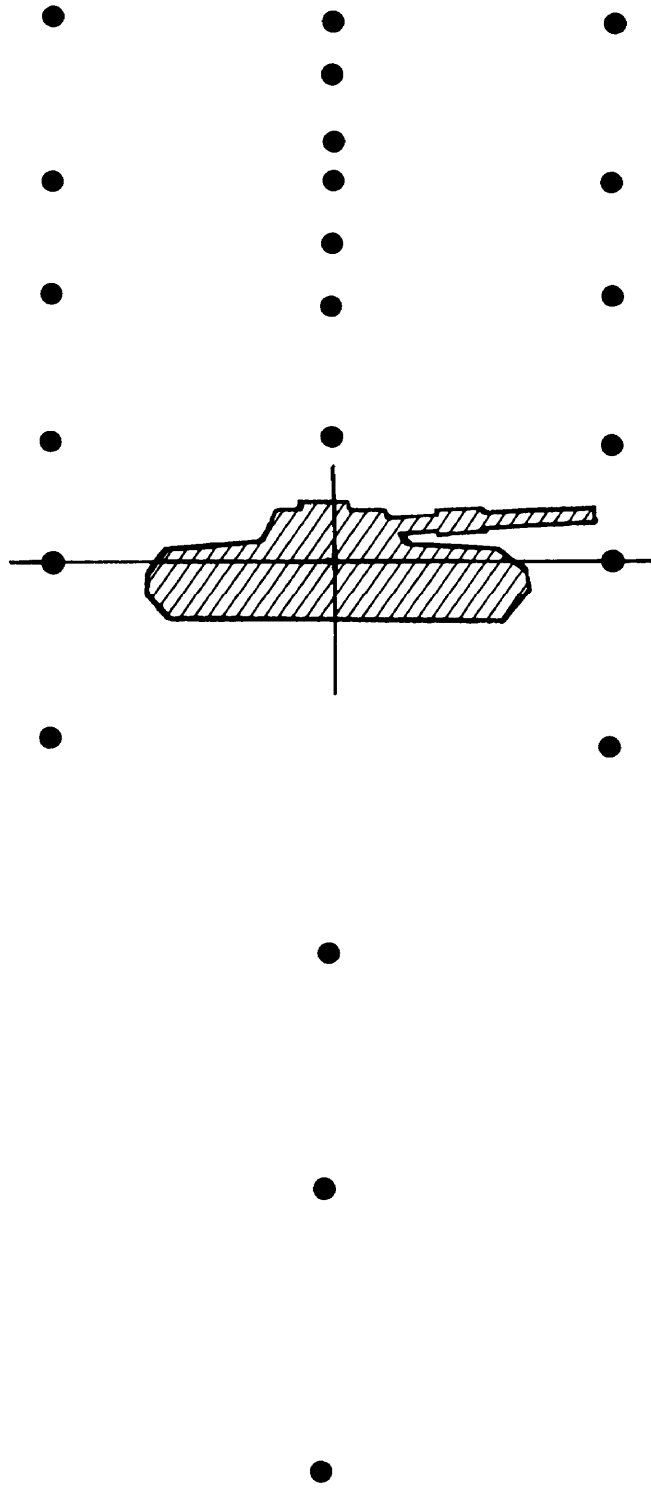
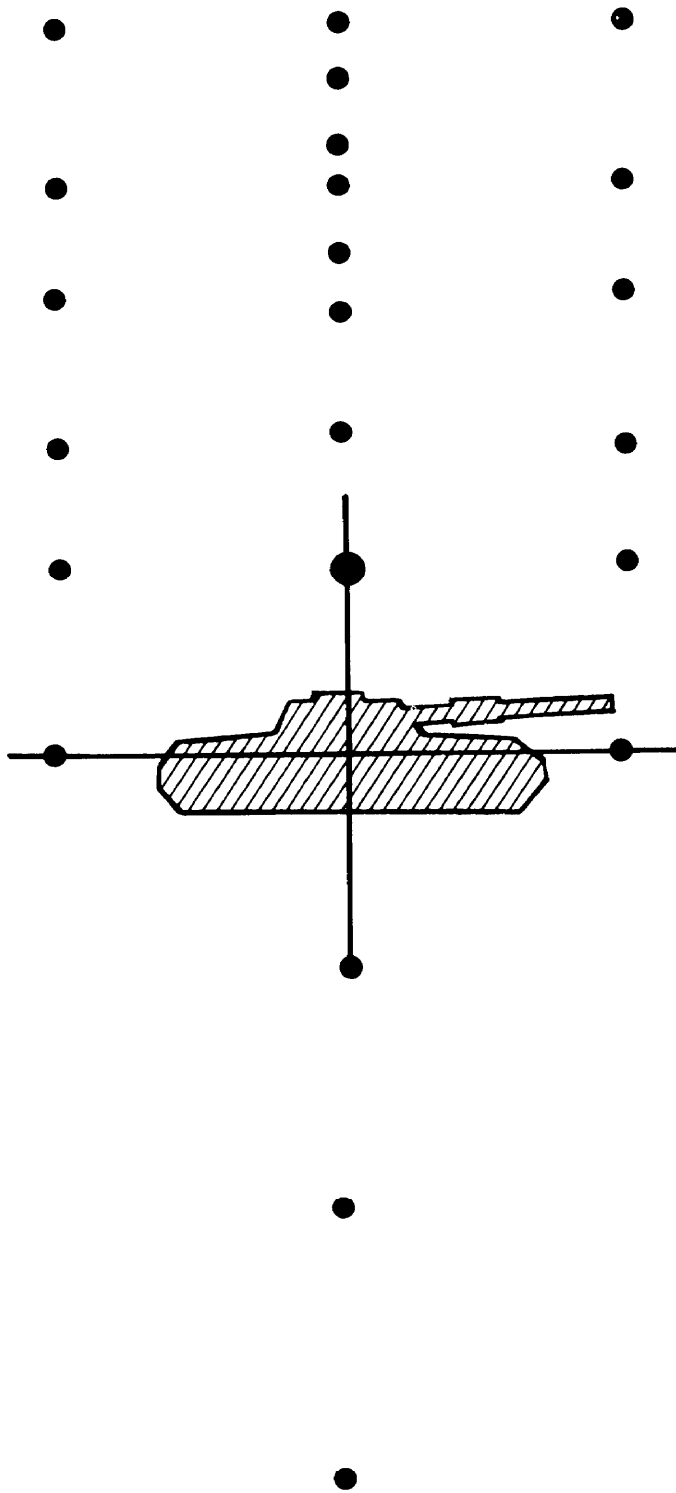

Figure 12. 106-mm rifle spotting gun burst-on-target.



②
Figure 12—Continued.



①
Figure 13. 106-mm rifle spotting gun observation of tracer.

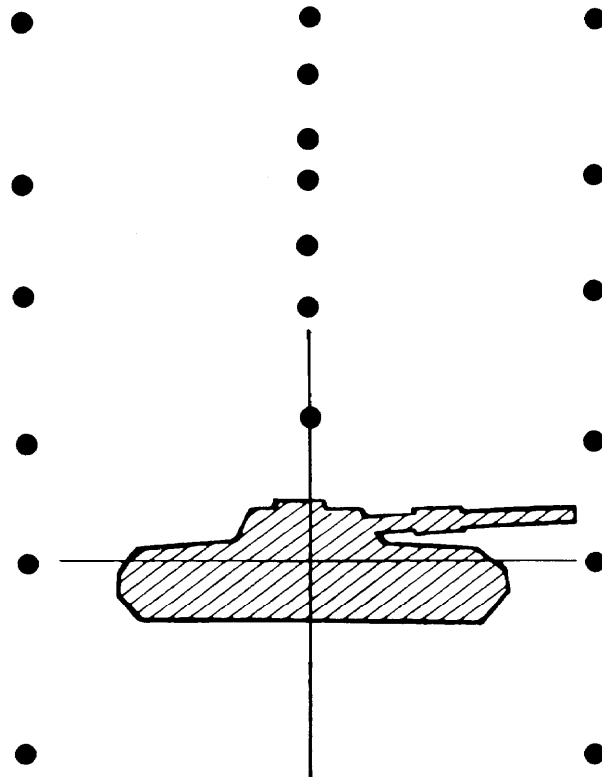

②
Figure 13—Continued.

CHAPTER 6

MARKSMANSHIP TRAINING

Section I. INTRODUCTION

44. General. Marksmanship training for the Crew-Served Weapon Night Vision Sight must be considered as a continuation of gunner training received by gunners with their assigned weapons. To effectively employ the Sight, the gunner must first master the fundamentals of marksmanship for his particular weapon. This chapter explains marksmanship training as it applies to the Sight. For a detailed description of marksmanship train-

ing for the weapon on which the Sight is mounted, refer to FM 23-82 and FM 23-65.

45. Purpose of Marksmanship Training. Preparatory marksmanship training teaches essential skills and develops fixed and correct habits before range firing begins. Through instruction and carefully supervised practice in the preparatory phase, time and ammunition are saved during range firing.

Section II. PREPARATORY MARKSMANSHIP

46. Browning Machinegun Caliber .50 HB M2 *a. Sighting and Aiming.*

- (1) To aim for range, select the correct range segment of the vertical line on the reticle and place it at the center base of the target. Figure 14 depicts a vehicle at a range of 400 meters with the correct sight picture. Since the reticle dots are placed in 200-meter intervals, engagement of targets at other ranges requires interpolation. For example, a target at a range of 500 meters would be engaged as depicted in figure 15.
- (2) The reticle dots of the Sight are not numbered; therefore, the gunner must remember their value and then lay on various targets. To develop skill in the proper selection of range dots and correct sight picture, preparatory sighting exercises must be conducted. The first sighting and aiming exercises may be conducted in classroom or training areas under daylight or night conditions. To conduct these exercises, mount the gun and Sight on the tripod mount and place a target at any range (at night any visible range) in front of the gun. During daylight

hours, insure that the boresight cover is used. A trained individual acting as a coach will announce the range to the target in even hundreds. The gunner places the announced reticle dot on the target by manipulating the traversing and elevating mechanism of the gun. When the gunner is satisfied with the lay of his gun he will announce UP. The coach will then check the Sight picture and make the necessary corrections. Once the gunner is proficient in these exercises he will progress to ranges requiring interpolation by using the spaces between the reticle dots. Interpolation exercises are conducted in the same manner as described above.

- (3) Aiming with leads. The average speed of a moving vehicle at night, under blackout conditions, is considered to be 5 miles per hour; therefore, a 5-mil lead right and left of center is provided on the Sight reticle. To engage a target moving directly across the gunner's front, place the lead dot corresponding to the range on the leading edge of the vehicle. In figure 16 the vehicle was determined to be at a

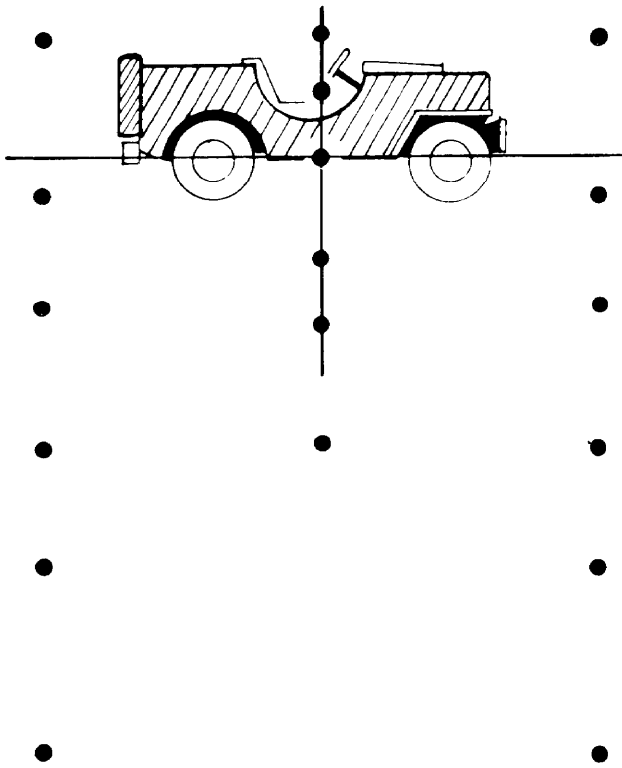

Figure 14. Sight picture (400 meters), caliber .50 machinegun.

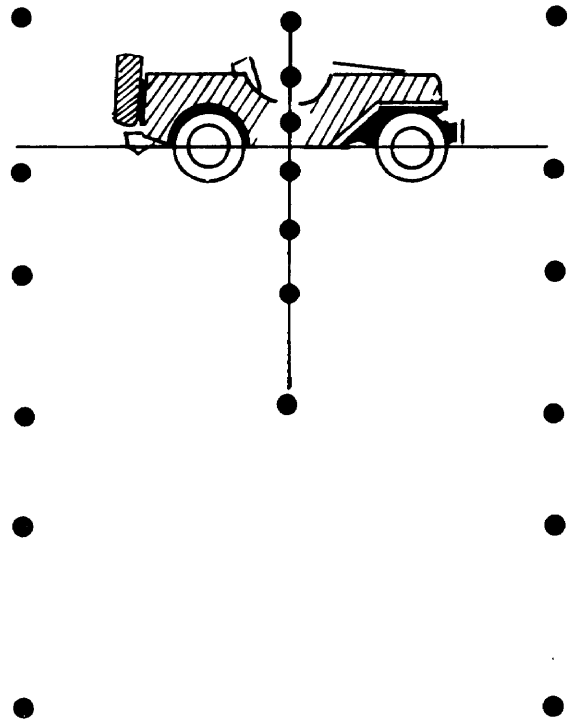

Figure 15. Sight picture (500 meters), caliber .50 machinegun.

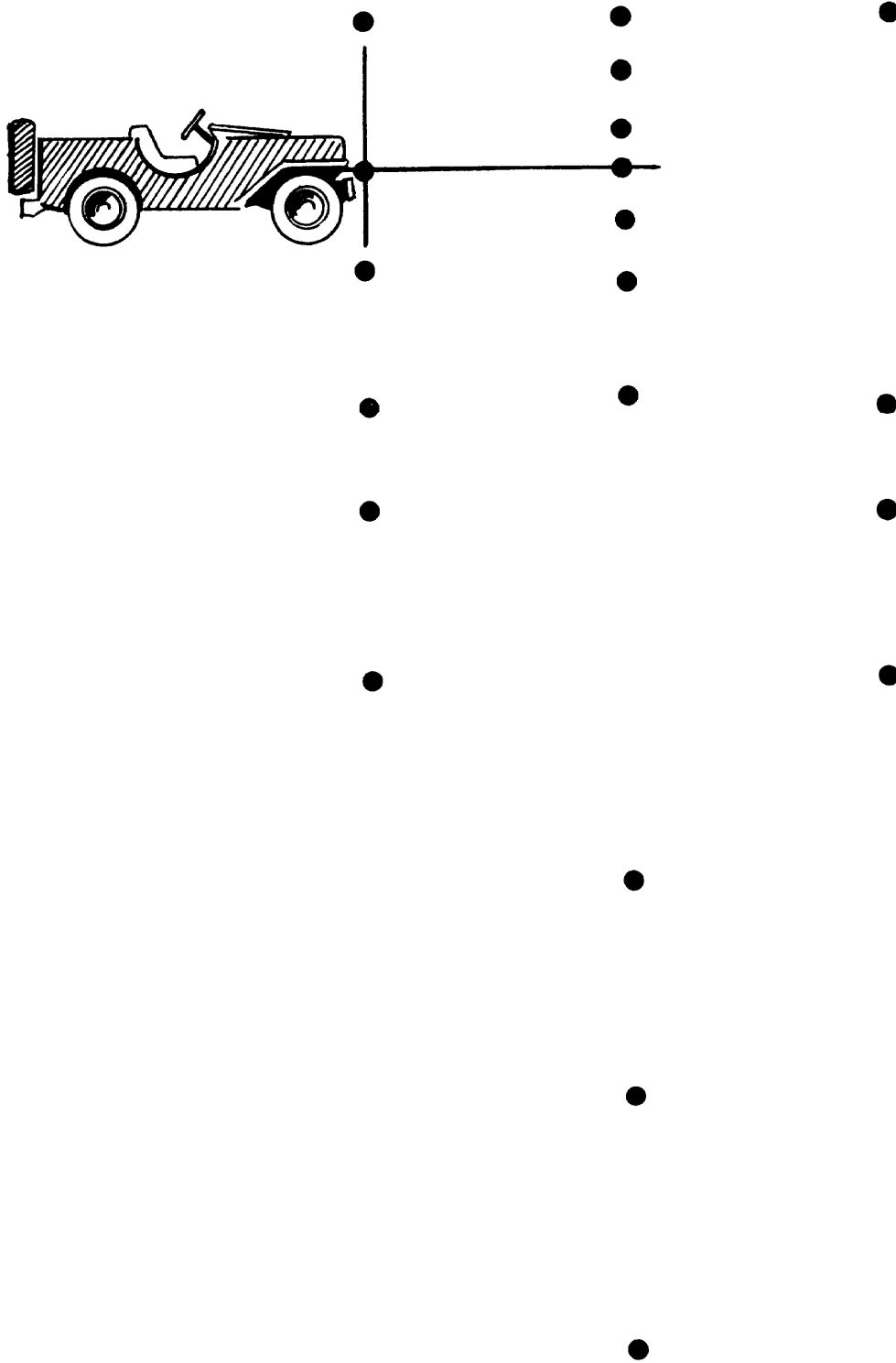

Figure 16. Aiming for leads, caliber .50 machinegun.

range of 600 meters and moving 5 miles per hour. Lead exercises are conducted as outlined in (2) above; however, direction of travel must be included.

b. Gunner Positions, Caliber .50 Machinegun.

- (1) *Prone position (fig 17).* The prone position is possible with the Sight mounted on the caliber .50 machinegun; however, it is not recommended because it requires the gunner to hold his head in an unnatural position and results in fatigue. To assume this position, the front leg of the tripod must be moved to the extreme low position, thus limiting the amount of elevation available on the elevating mechanism.
- (2) *Sitting position (fig 18).* The sitting position is the normal position used with the Sight when the caliber .50 machinegun is on the tripod mount. To assume this position, the gunner sits between the rear legs of the tripod with his legs crossed or extended. The knees are raised and turned outward. The elbows are placed on the inside of the thighs. The right hand is placed on the spade grip and the left hand palm down on the elevating handwheel. Place the right eye

firmly against the rubber eyeshield of the Sight. Exert a steady pressure down with the left hand while aiming and firing.

- (3) *M113 turret mount position (fig 19).* Place both hands on the spade grips, move body forward, and lock elbows into sides with chest against the spade grips. Place the right eye against the rubber eyeshield. Brace the body and arms firmly and aim low on the target, as the muzzle has a tendency to rise during firing.

47. Preparatory Marksmanship, 106-MM Recoilless Rifle. *a. Sighting and Aiming.*

- (1) Since the reticle of the Sight is a multiple reticle and the aiming dots for this weapon are off center, the gunner is required to select the correct range dot and then obtain the correct Sight picture in the center of the Sight reticle. For example, the gunner determines the range to be 1,000 meters. He then aligns the target between the two 1,000-meter dots as shown in figure 20. The interval between the reticle dots is 200 meters; therefore, targets at other ranges require both range and center line interpolation. For example, a tank at a range of 900

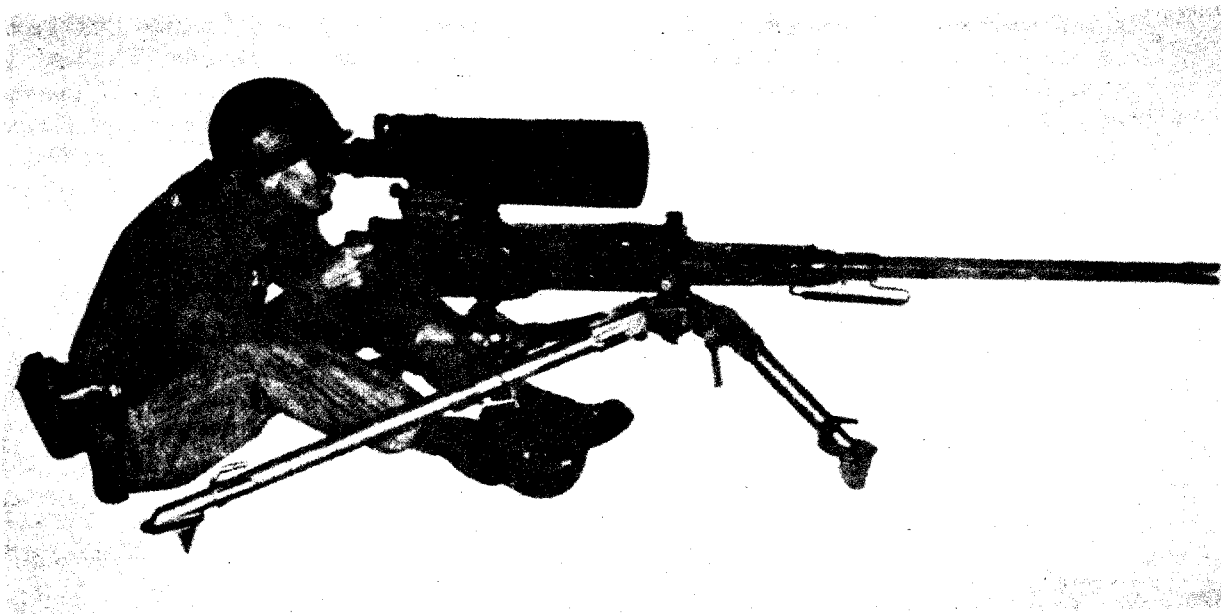

Figure 17. Prone position, caliber .50 machinegun.



① *Cross ankle.*

Figure 18. Sitting position, caliber .50 machinegun (tripod mount).



② *Legs extended.*

Figure 18—Continued.

meters would be engaged as depicted in figure 21. To engage targets at ranges of 1,200, 1,400, and 1,600 meters, lay on the appropriate dot as shown in figure 22.

- (2) Since the reticle dots are not numbered, the gunner must remember their value

and then lay on the various targets. To develop skill in the proper selection of range dots, interpolation, and correct Sight picture, preparation exercises must be conducted. The first exercises may be conducted in any suitable training area

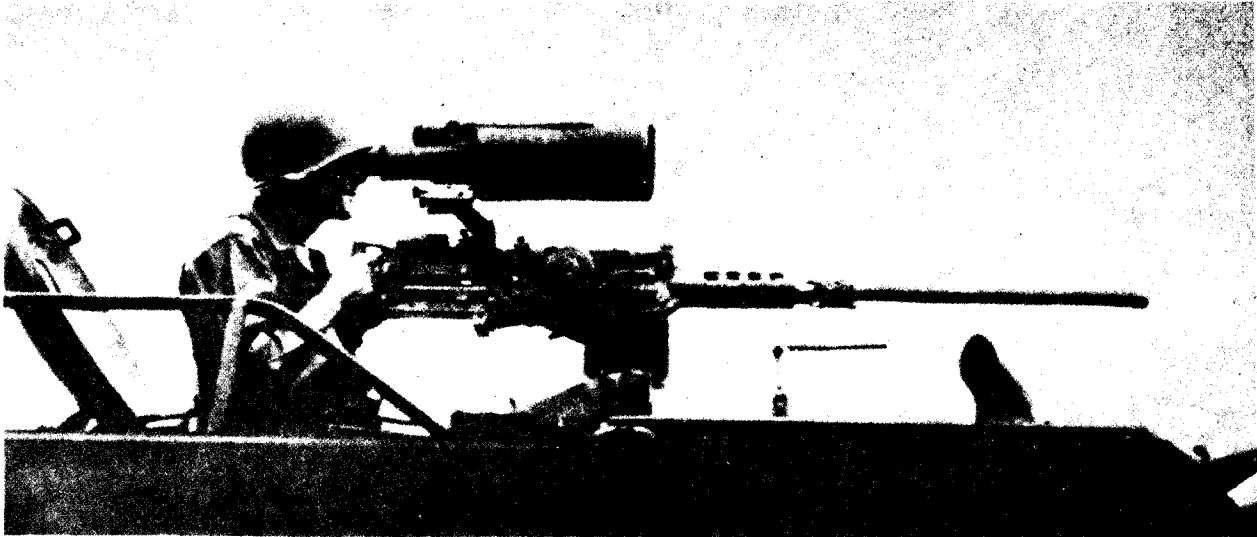

Figure 19. Gunner's position, caliber .50 machinegun (turret mount M113).

under daylight or night conditions. To conduct these exercises, mount the Sight on the weapons system and place an appropriate target at any range (at night any visible range) in front of the weapon. During daylight hours, insure that the boresight cover is used. A trained individual acting as coach will announce the range to the target in even hundreds and require the gunner to lay the weapon on the announced range. When the gunner is satisfied with his Sight picture, he will announce UP. The coach will then check the Sight picture and make necessary corrections. He will then continue announcing ranges in even hun-

dreds until the gunner can obtain the correct Sight picture. Once the gunner is proficient in these exercises, he will progress to ranges requiring both range and center line interpolation.

- (3) Aiming for leads. The same methods and exercises used with the caliber .50 machinegun are used with 106-mm rifle, except that the lead dot is placed in the center of mass of the target instead of the leading edge (para 46).

b. Gunner's Position 106-MM Recoilless Rifle (Fig 23). The same position used with the M92D sight is used with the Crew-Served Weapon Night Vision Sight, except the head must be moved forward.

Section III. SAFETY PRECAUTIONS, RANGE AND FIRING PROCEDURES

48. 106-MM Recoilless Rifle. The safety precautions and range and firing procedures outlined in FM 23-82 apply to firing with the Crew-Served Weapon Night Vision Sight with the following exceptions:

- a.* The feeder will use a flashlight with red filter in place of a red flag.
- b.* Red lanterns will be placed on the fenced or roped area of the firing line with lights pointing out to warn personnel of danger area.
- c.* Range guards must be instructed to warn

personnel entering the range of danger areas and their markings.

d. Each scoring officer and/or noncommissioned officer will have two flashlights, one with a red filter and one without. When his gun position is ready UP, he will turn the flashlight without a filter to the range officer and hold the light until this signal is acknowledged by the range officer. The red filter flashlight at each gun position will be used to signal emergencies and to cease fire.

49. Caliber .50 Machinegun. *a. Safety Precautions.*

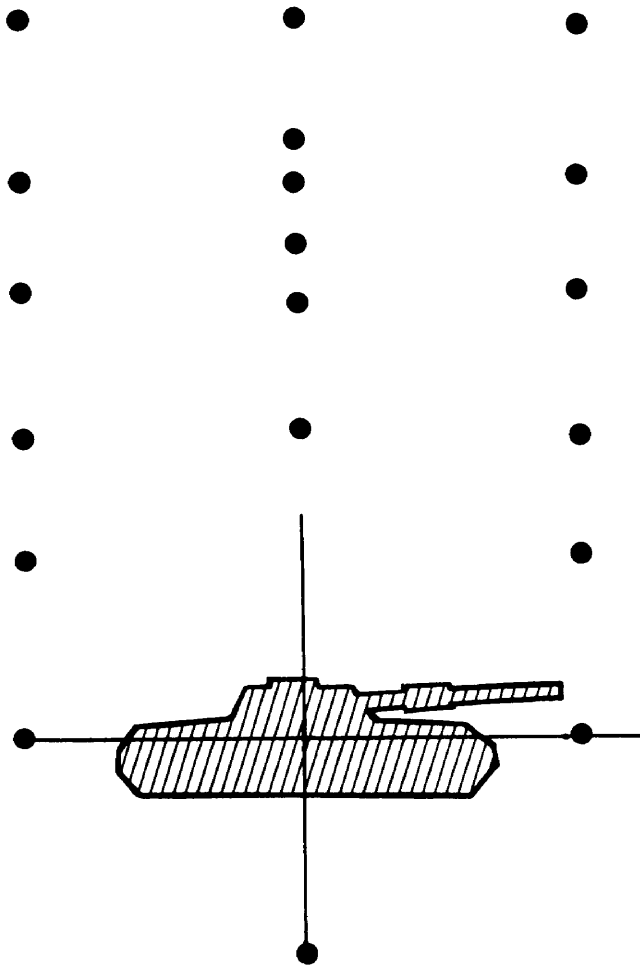

Figure 20. Sight picture, 106-mm rifle.

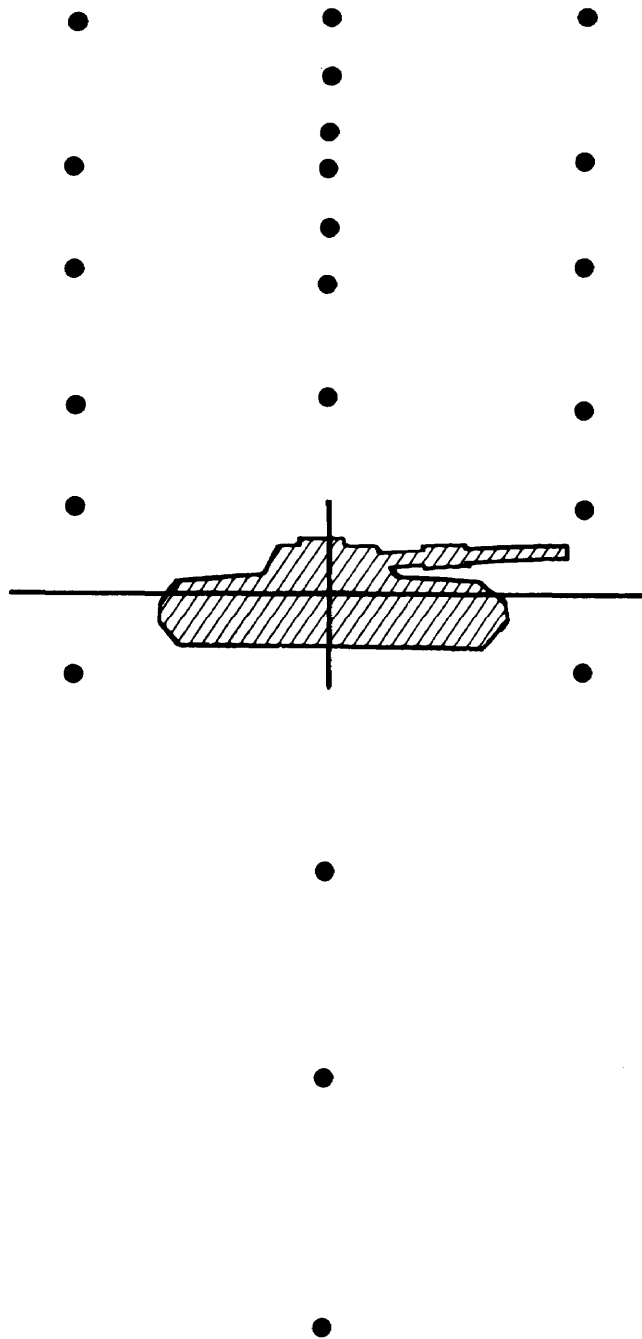

Figure 21. Sight picture, 106-mm rifle.

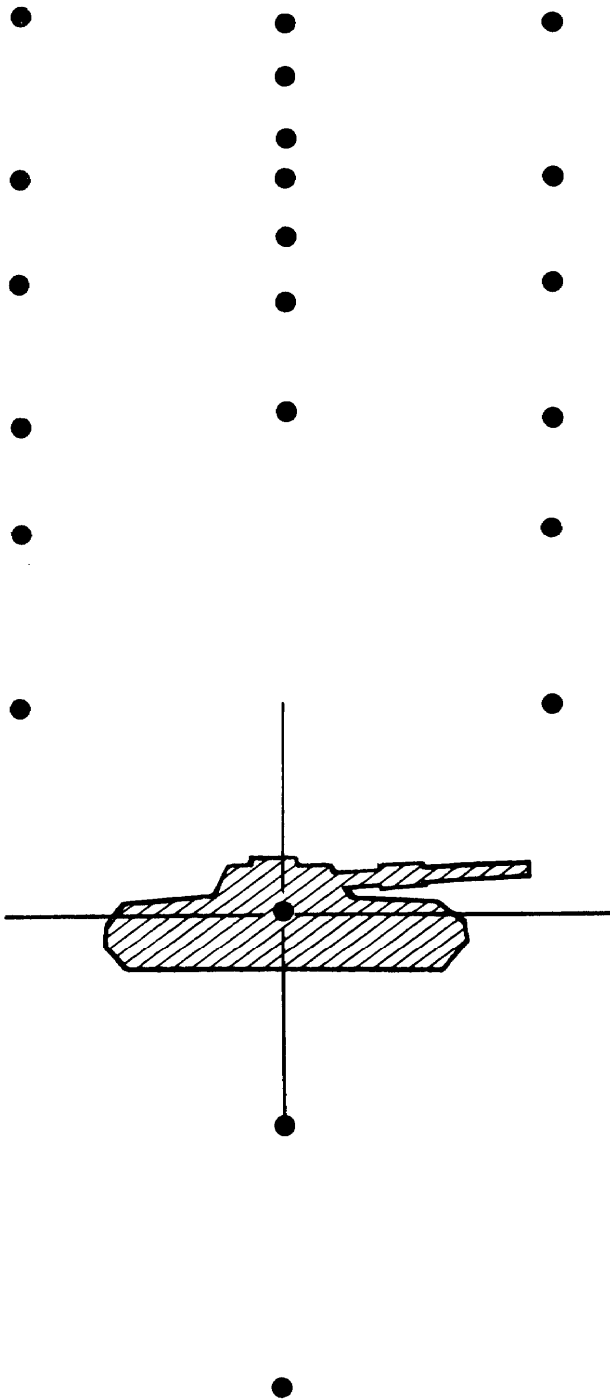

Figure 22. Sight picture, 106-mm rifle.

- (1) Safety procedures are outlined in AR 385-63 and local range regulations.
- (2) Headspace and timing for each weapon used must be personally checked by the range officer before firing.
- (3) Red lights must be placed down range at the right and left limits of the range fan.
- (4) Red lights must be placed at the right and left limits of the firing line and facing to the rear to warn personnel of the danger area.
- (5) Range guards must be instructed to warn personnel entering the firing area of danger areas and their markings.
- (6) Since the safety officers and/or noncommissioned officers cannot see the guns at night, stakes or poles can be placed to the right and left of gun barrels to insure that firing is within the range fan.
- (7) Each safety officer and/or noncommissioned officer will have two flashlights, one with a red filter and one without. When his gun(s) is ready UP, he will turn the flashlight without the filter to the range officer and hold the light until his signal is acknowledged by the range officer. The red filter flashlight will be used to signal emergencies and to cease fire.
- (8) The weapon is considered safe when the bolt is to the rear, cover up, and clearing block inserted in the receiver after a cleaning rod had been passed through the bore.

b. Range and Firing Procedures.

- (1) During all firing exercises, emphasis should be placed on rapid adjustment of fire with a second round target hit as a minimum goal.
- (2) Range safety officers and/or noncommissioned officers must continuously observe and make corrections during all firing to insure maximum effectiveness of training.
- (3) During the initial phases of familiarization firing, the range officer may, at his

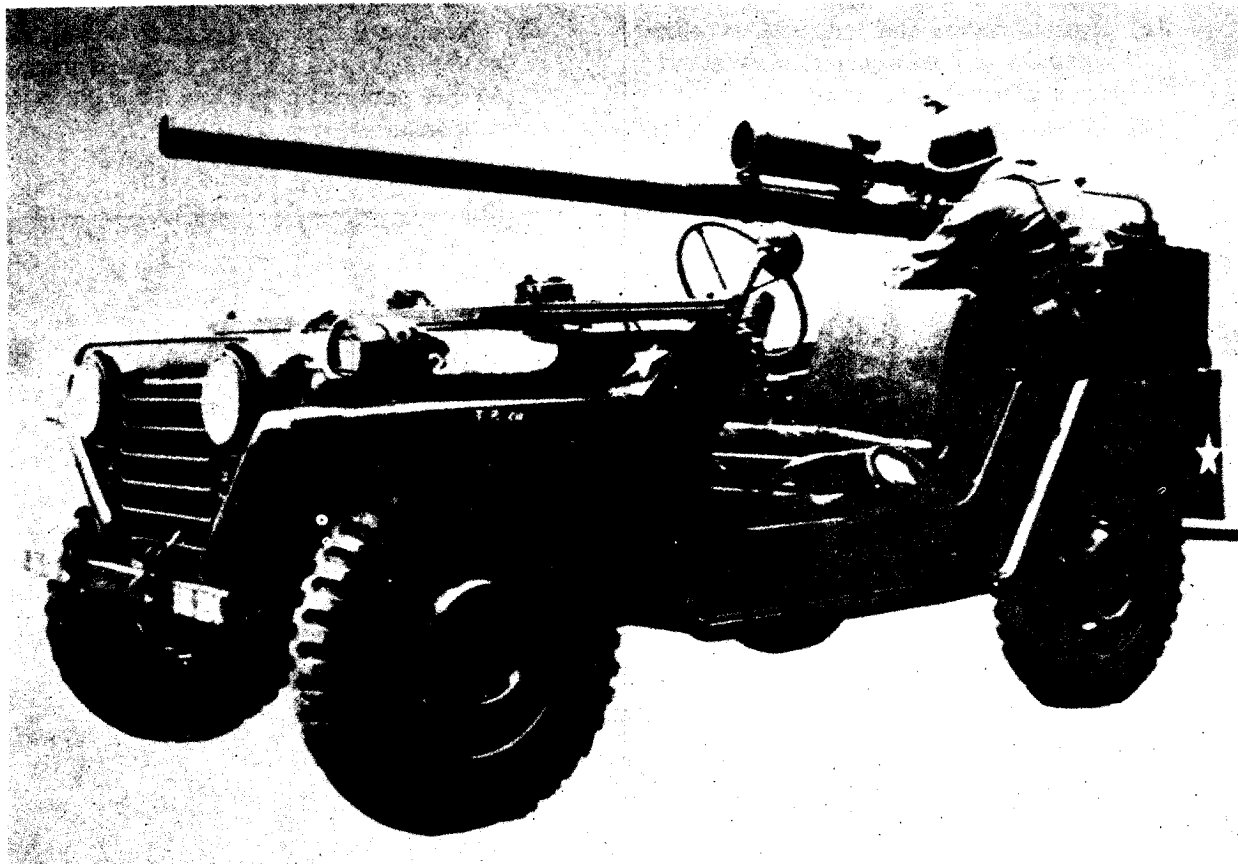

Figure 23. Gunner's position, 106-mm rifle.

- own discretion, reduce the speed of the target and the number of rounds fired for each run. The object of this is to increase confidence, place emphasis on manipulation of the traversing and elevating mechanism, and accuracy.
- (4) When conducting table IV (para 54 *b*), those gunners not actively engaged in firing will conduct dry fire exercises.
 - (5) The range officer is responsible for the following:
 - (a) Assigns, coordinates, and supervises the firing line.
 - (b) Personally checks headspace and timing of each weapon prior to firing.
 - (c) Issues fire commands and general instructions to the firing line.
 - (d) Enforces safety regulations prescribed in AR 385-63, local range regulations, and safety precautions outlined in paragraph 48.
 - (e) Organizes the range.
 - (6) Safety officer and/or noncommissioned officer is responsible for the following:
 - (a) Insures that all safety regulations are complied with at his gun position(s).
 - (b) Notify the range officer when his weapon(s) is ready UP.
 - (c) Observes each firing exercise, critiquing and correcting each gunner firing.
 - (7) Coaches (assistant gunners) are responsible for the following:
 - (a) Assists the gunner in loading of the weapon.

TC 23-13

- (b) Requires his gunner to observe all range safety regulations.
- (c) Repeats orders and instructions when necessary to insure correct understanding and timely execution.
- (d) Reports stoppages, malfunctions, or

discrepancies to the safety officer and/or noncommissioned officer.

- (8) Organization of the range is as follows:
 - (a) See figure 24 for range organization.
 - (b) See paragraph 48 c and d for duties of personnel.

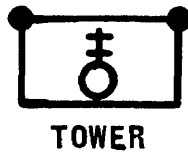
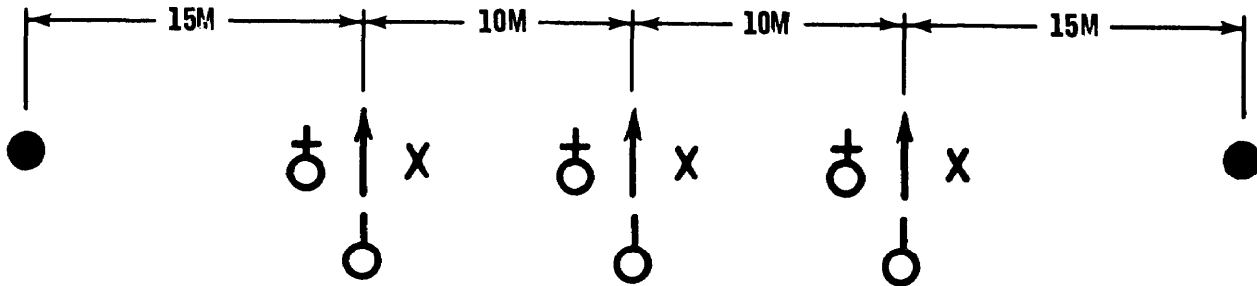

LEGEND:





-  GUNNER
-  ASSISTANT GUNNER (COACH)
-  SAFETY OFFICER / NCO
-  RED LIGHTS
-  OFFICER IN CHARGE

Figure 24. Range organization, caliber .50 machinegun.

CHAPTER 7

MARKSMANSHIP

Section I. OPERATOR'S COURSE, CREW-SERVED WEAPON NIGHT VISION SIGHT MOUNTED ON THE 106-MM RECOILLESS RIFLE

50. General. *a.* Preliminary instruction, before range firing, consists of at least 4 hours. It includes characteristics, mechanical training, installation, operation, boresighting, preliminary marksmanship training, and factors affecting employment. The range firing will consist of firing tables I and II. ASubjScd 23-13 should be consulted for detailed information regarding the conduct of training.

b. Fundamentals emphasized in the firing course are:

- (1) Rapid and accurate firing of initial cartridge.
- (2) Rapid and accurate firing of subsequent rounds.
- (3) Rapid and accurate adjustment of fire.
- (4) Use of the spotting gun to determine range.

51. Range Firing Tables. *a. Table I: 25-meter Subcaliber, Stationary Target Range.*

- (1) *Purpose.* This table is designed to test the gunner's ability to obtain the correct Sight picture.
- (2) *Physical layout.* The exercise is fired on the standard 25-meter range, or any other suitable firing area. The target used is the standard E-type silhouette. From white paper, cut three 4-inch tank silhouettes for each E-type target as shown in figure 25.
- (3) *Equipment.*
 - (a) 106-mm rifle: 3 (minimum).
 - (b) Subcaliber device caliber .30 (106-mm rifle): 3 (minimum).
 - (c) Crew-Served Weapon Night Vision Sight: 3 (minimum).

(4) *Ammunition.* Use caliber .30 ball, M2.

(5) *Conduct of firing.*

(a) Since the gunner is required to obtain three different sight pictures when firing this table, a minimum of three 106-mm rifles are required to fire the exercise. The number of guns required to fire the exercise will vary with the number of personnel to train and the amount of equipment available, but will increase in multiples of three.

(b) The weapons may be zeroed prior to the arrival of students, since subcaliber zeroing has no tactical significance. The guns are numbered gun 1, gun 2, and gun 3. Gun 1 is zeroed at 600 meters, gun 2 is zeroed at 900 meters, and gun 3 is zeroed at 1,200 meters.

(c) The range officer issues the following fire commands:

FIRE MISSION :

GUN 1, 600.

GUN 2, 900.

GUN 3, 1,200.

TANK.

FIRE.

(d) Upon receipt of the fire command the gunners engage the three tank silhouettes on their respective targets without further command. The No. 1 gunner uses the 600-meter reticle dot, the No. 2 gunner uses the 900-meter reticle setting, and the No. 3 gunner uses the 1,200-meter reticle dot.

(e) Coaches and instructor personnel check

targets and critique gunners. A hit anywhere on the tank silhouette is considered as a hit; however, gunners should strive for a center of mass hit.

- (f) The gunner rotates to the next gun position and fires the same exercise using that gun reticle setting until he completes all three exercise.
- (g) Gunners who experience difficulty obtaining hits during these exercises are given additional training by *dry firing* the exercise and then firing the exercise

again at slow fire before progressing to the fast rate.

- (h) The gunner then fires the same exercise while being timed. For the fast rate, the gunner is allowed 15 seconds for each tank engagement.
- (i) The exercise should be fired at night for the best possible training. However, the exercise may be fired during daylight hours by using the boresight cover.
- (j) Stationary target.

Table I. 25-meter subcaliber firing, stationary target

Trial	Traverse	Zero range setting (meters)	Number of cartridges	Time (seconds)
Zero	Fixed	600	3	None
1	Slow	600	3	None
Zero	Fixed	900	3	None
2	Slow	900	3	None
Zero	Fixed	1, 200	3	None
3	Slow	1, 200	3	None
4	Fast	600	3	45
5	Fast	900	3	45
6	Fast	1, 200	3	45
Total			27	

b. Known Distance Firing, Service Ammunition (Table II).

- (1) *Purpose.* This table is designed to test the gunner's ability to obtain the correct Sight picture, adjust his fire by using the burst-on-target method, observation of tracer, and the spotting gun method, while firing caliber .50 spotter tracer and service ammunition.
- (2) *Physical layout.* The exercise is fired on the standard known distance service firing range. Tank hulls, log bunkers and/or other targets of sufficient density to cause the caliber .50 spotter-tracer and 106-mm rifle projectiles to detonate will be used. These targets should be placed at ranges of 600, 700, 800, and 1,200 meters.
- (3) *Equipment.*
 - (a) 106-mm rifle.
 - (b) Crew-Served Weapon Night Vision Sight.

- (c) Boresighting equipment.
- (4) *Ammunition.* Use caliber .50 spotter-tracer and service ammunition.
- (5) *Conduct of firing.*
 - (a) Boresight the 106-mm rifle with the Crew-Served Weapon Night Vision Sight. Zero the spotting gun with the Crew-Served Weapon Night Vision Sight at 1,100 meters.
 - (b) Since the exercise is fired at night, the coach should have a Starlight Scope to critique the firing of his gunner.
 - (c) The exercise is fired twice; however, service ammunition will be fired only on the second firing. Those gunners experiencing difficulty obtaining hits during the first firing should be given additional *dry fire* training before firing again.
 - (d) Known distance firing:

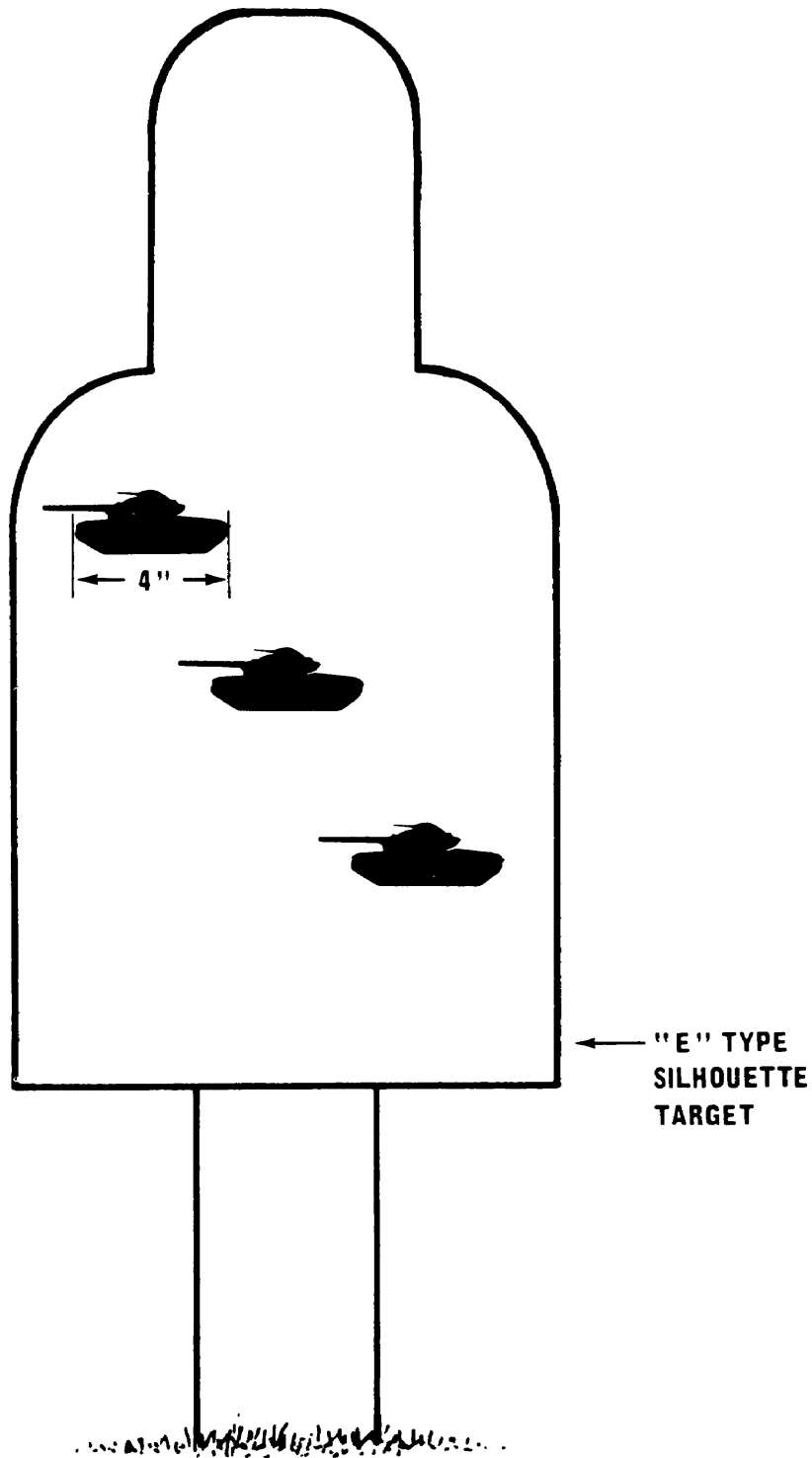

Figure 25. Target construction, 106-mm rifle, 25-meter range.

Table II. Known distance firing, service ammunition

Caliber .50 (spotter-tracer)	Service (cartridge)	Range (meters)	Target
6-----	0	1, 100	Zeroing.
2-----	*1	600	Use tank, hulls, log bunkers, and/or other targets of sufficient density to cause the caliber .50 spotter- tracer and 106-mm rifle projectiles to detonate.
2-----	*1	700	
2-----	*1	800	
2-----	*1	1, 200	
Total 14 rounds.	4		

*Second firing only.

52. Proficiency Course. *a. General.* This course is designed for gunners who have previously received the operator's training course, as outlined in paragraph 50.

b. Preliminary instruction before range firing consists of a 2-hour review on installation and operation, boresighting, preliminary marksmanship training, and up-to-date changes on modifications to the Sight.

c. The firing course consists of firing table II once, without service ammunition.

d. For a detailed outline of the instruction given, instructors should refer to ASubjScd 23-13.

Section II. OPERATOR'S COURSE, CREW-SERVED WEAPON NIGHT VISION SIGHT MOUNTED ON THE CALIBER .50 MACHINEGUN

53. General. *a.* Preliminary instruction on the Sight before range firing consists of at least 4 hours of instruction. This instruction includes characteristics, mechanical training, installation, operation, boresighting, maintenance, preliminary marksmanship training, and factors affecting employment. The firing courses will consist of tables III and IV. These courses may be modified to coincide with the limitations imposed by local range facilities. For infantry units, firing will be conducted with the machinegun on its tripod mount. Mechanized units will fire the course with the weapon mounted on the tripod for table III and mounted on the M113 armored personnel carrier for table IV.

b. Fundamentals emphasized in the range firing course are:

- (1) Rapid determination of range.
- (2) Rapid engagement of successive target
- (3) Rapid and accurate adjustment of fire.

54. Operator's Training Course Tables. *a. Table III. 10-Meter Firing.*

- (1) *Purpose.* This table is designed to test the gunner's ability to obtain the correct Sight picture.
- (2) *Physical layout.* The M60 machinegun basic 10-meter range may be used if range clearance is extended to 6,800 meters or a berm is placed behind the target line.

Any caliber .50 machinegun range can be used, provided a reasonably smooth area extends out to 10 meters in front of the firing line. The M60 machinegun basic 10-meter target is used on this range.

- (3) *Equipment.* Army Subject Schedule 23-13.
- (4) *Ammunition.* Use ball, M2, caliber .50 MLB.
- (5) *Conduct of firing.*
 - (a) Pastors 1 and 2 are used to zero. To fire trials 1 and 2, zero the sight by using the 800-meter reticle dot.
 - (b) Upon completion of zeroing, the range officer issues a fire command for the engagement of pasters 3, 4, 5, 6, 7, and 8.

FIRE MISSION :

FRONT.
PASTERS 3, 4, 5, 6, 7, AND 8.
800.
FIXED.
NO TIME LIMIT.
AT MY COMMAND.

- (c) When trial 1 has been completed by all firers, the coach and gunner will move forward and critique the firing. A round anywhere within the scoring space is considered as a hit. Those

gunners experiencing difficulty during this trial should receive additional training by dry firing the exercise.

- (d) Trial 2 is conducted in the same manner except that the gunner is allotted 60 seconds to fire the exercise.
- (e) Trials 3 and 4 are conducted as outlined in (b), (c), and (d) above except the gunner uses the 500-meter reticle

setting. The purpose of firing this exercise is to give the gunner practice in setting ranges which require interpolation between reticle dots.

- (f) The exercise is fired at night for the best possible training. The exercise may be fired in daylight hours using the boresight cover.
- (g) Table III. 10-meter firing.

Table III. 10-meter firing

Trial	Traverse	Zero range setting	Number of cartridges (meters)	Time (seconds)	Type of fire
Zero.....	Fixed.....	800	3	None.....	Single shot all exercises.
1.....	Slow.....	800	6	None.	
2.....	Fast.....	800	6	60.	
Zero.....	Fixed.....	500	3	None.	
3.....	Slow.....	500	6	None.	
4.....	Fast.....	500	6	60.	
Total.....			30		

b. Table IV. Transition Range.

- (1) *Purpose.* This table is designed to test the gunner's ability to adjust fire by using the burst-on-target and the observation-of-tracer methods.
- (2) *Physical layout.* Any .50 caliber machinegun range may be used by placing a tank or other vehicular targets down range as shown in figure 26.
- (3) *Equipment.*
 - (a) Caliber .50 machineguns,
 - (b) Crew-Served Weapon Night Vision Sight (1 per gun).
 - (c) Field expedient boresight device (as described in para 26a).
 - (d) Starlight Scope (1 per coach).
- (4) *Ammunition.* Use ball, caliber .50, Tr-4-1 MLB.
- (5) *Conduct of firing.*
 - (a) Boresight weapons as outlined in paragraph 26a.
 - (b) This exercise is fired at night.

- (c) The officer in charge issues the following fire command for firing trial 1:
FIRE MISSION:
FRONT.
TANK.
AT MY COMMAND.
- (d) During trial 1, the gunners will engage all targets in their sector without further command. Each target is engaged single shot, with a maximum of four rounds per target.
- (e) Upon completion of this firing, the coach will critique the firing of his gunner. Those gunners experiencing difficulty during this trial will be given additional dry firing and then will fire trial 1 again.
- (f) Trial 2 is fired in the same manner as trial 1 except the gunner fires in six-round bursts and is allowed 216 seconds to fire the exercise.
- (g) Table IV. Transition range:

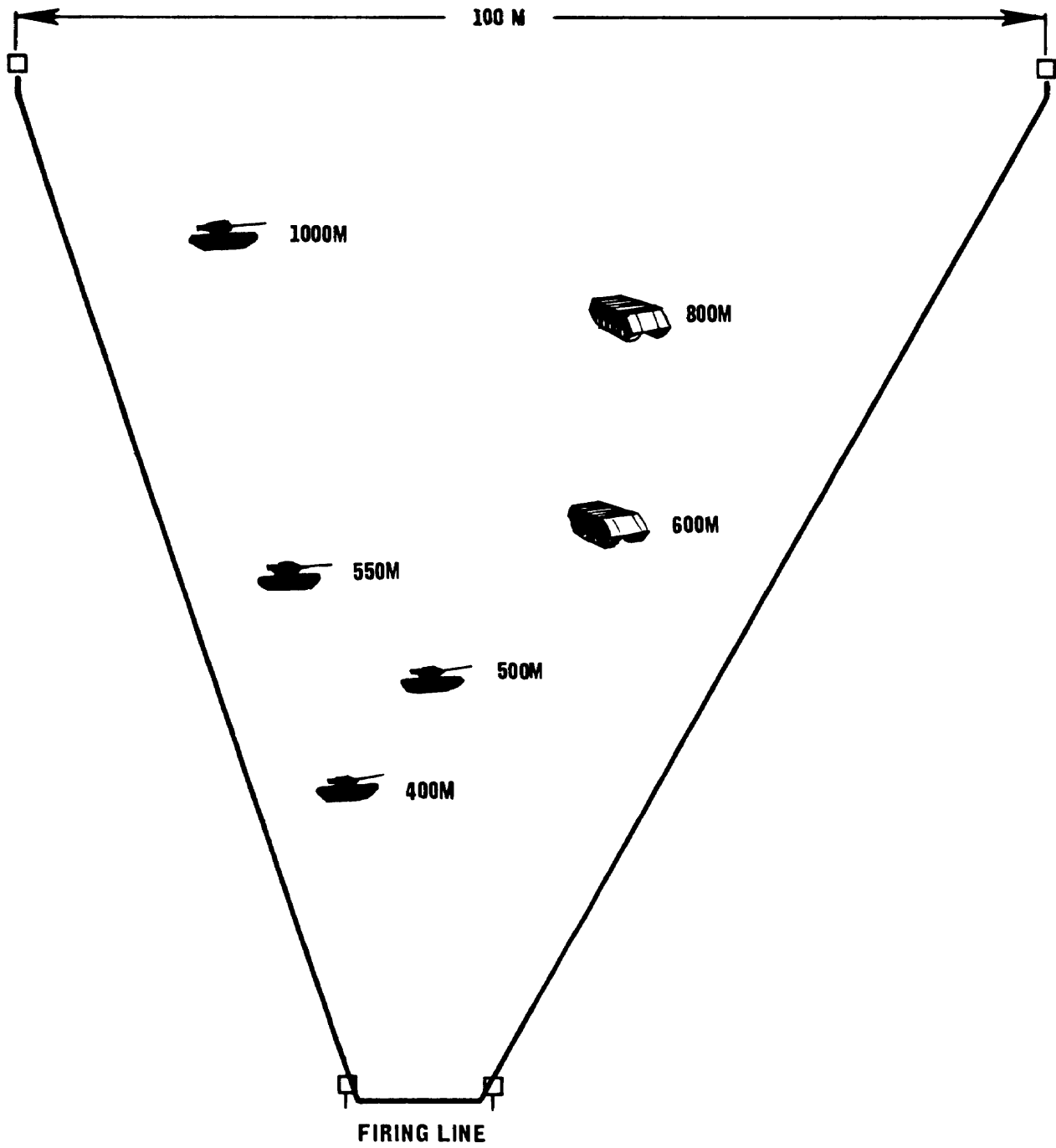

Figure 26. Range layout, transition range.

Table IV. Transition range

Trial	Range (meters)	Time (seconds)	Total rounds	Target	Type of fire
1.....	400-600	None.....	24	Tank, vehicle, or log bunker. Minimum of six targets.	Single shot. Four rounds per target.
2.....	400-600	216.....	72	Tank, vehicle, or log bunker. Minimum of six targets.	Fixed fire of two 6-round bursts per target.
Total.....			96		

55. Proficiency Course. *a. General.* This course is designed to retrain gunners who have previously received the operator's course outlined in paragraph 53.

b. Preliminary instruction before range firing consists of 2 hours review on installation and operation, boresighting, preliminary marksman-

ship training, and up-to-date changes or modification of the Sight.

c. The firing course consists of firing table IV once.

d. For a detailed outline of the instruction given, see Army Subject Schedule 23-13.

CHAPTER 8

FACTORS AFFECTING EMPLOYMENT

56. General. The basic purpose of the Sight is to provide an efficient, secure viewing capability for friendly forces during the conduct of night operations. Although the Sight does not give the soldier the width, depth, or clarity of daylight vision, he can see well enough to aim and fire his weapon; observe the effects of his fires; observe the terrain, the enemy, and his own forces; and perform numerous other tasks that confront a soldier in the field at night. Proper use of the Sight will permit more effective execution of night offensive and defensive operations, aid in coordination and control within units, boost morale, and promote troop confidence.

57. Factors Affecting Employment. *a. Light.* Since the Sight is dependent upon the ambient light level of the night sky, the most effective operation can be expected under conditions of bright moonlight and starlight. As the ambient light level decreases, so does the effectiveness of the Sight. When the ambient light level is low (sky overcast with no starlight or moonlight), the efficiency of the Sight can be greatly increased when it is used with visible light, such as that produced by searchlights employed in their indirect role. The use of flares or illuminating shells on the flanks or to the right or left front will also aid during periods of low illumination. When the Sight is employed with artificial illumination, the depth and clarity of vision are vastly superior to that experienced by the naked eye under similar light conditions.

b. Atmospheric Condition. Clear nights provide the best operating conditions for the Sight. When used under conditions such as rain, sleet, snow, smog, or fog, the viewing capability is greatly reduced.

c. Terrain. To adequately describe the effects of terrain on the employment of the Sight, it is

necessary to approach the subject from several angles using different light conditions.

- (1) When viewing from open terrain into densely wooded terrain under moonlight or starlight conditions, penetration of the woods is limited to a few meters. The operator may experience difficulty in detecting targets with a dark background.
- (2) When viewing from open terrain into sparsely wooded terrain under moonlight or starlight conditions, penetration is greatly improved depending on the depth of the woods, height and location of the moon, and the distance of the system from the woods.
- (3) When viewing from densely or sparsely wooded terrain into open terrain under moonlight or starlight conditions, viewing capabilities are excellent.
- (4) When operating the Sight in open terrain under starlight or moonlight conditions, viewing capabilities are limited only by the ambient light level. The operator will experience little difficulty in target detection or identification under this condition.
- (5) Rivers, streams, and lakes.
 - (a) When using the Sight, to view on or across water under starlight conditions, the water appears as a void while the objects on the far bank appear as they normally do under starlight conditions.
 - (b) When using the Sight to view on or across water under moonlight conditions, the reflection of light from the water greatly increases the viewing capabilities of the Sight.
- (6) Most operators will initially experience eye fatigue after 15 to 30 minutes of continuous observation through the Sight.

However, after using the Sight several times within a given period, the operator's eyes may become accustomed to the green light, thus allowing him to observe through the night for longer periods of time. The operator may also alternate eyes during the viewing procedure to lessen eye fatigue.

(7) Light intensity.

(a) The Sight has an automatic cutoff switch incorporated into the image intensifier tube which will deactivate the tube when the light intensity is too high.

(b) Tracer ammunition is recommended for fire adjustment, but should be in a ratio of four ball and one tracer for five rounds when fired from machineguns. Tracer ammunition will deactivate the tube for a fraction of a second; however, this will not affect the operator's ability to adjust fires.

(c) Muzzle flash will also deactivate the Sight when mounted on the caliber .50 machinegun. This can be eliminated by using the flash suppressor.

58. Offensive Operations. The Sight may be used during night offensive operations to—

a. Select targets for supporting weapons, including mortars and artillery, and aid in the adjustment of this fire.

b. Maintain direction and control of attacking troops, provided communications with the attacking elements are established.

c. Speed advancement of the attacking elements

by aiding in locating and overcoming of obstacles en route.

d. Enhance control and improve efficiency of embarkation, crossing, and debarkation during river crossings or other types of amphibious operations.

e. Provide direct and observed fire on the objective throughout the attack.

59. Defensive Operations. The Sight may be used in a night defensive situation to—

a. Make possible the early detection and engagement of an attacking enemy.

b. Promote confidence of troops holding defensive positions by providing them with a capability of seeing at night.

c. Detect and destroy enemy patrols, infiltration teams, and guerrilla forces.

d. Identify friendly patrols and aid in their passage of lines by observation and signaling.

e. Select targets for indirect fire weapons and aid in the adjustment of these fires.

60. Employment Limitations. The employment of the Sight in night offensive and defensive operations is not limited to the methods described in paragraphs 58 and 59. The actual employment of the Sight will be limited only by the imagination of the users.

61. Selection of Positions. When using the Sight, it may require relocation of the gun position at night to obtain the best light conditions. Positions should be closer to the woodline and on level or below level of any possible target. The Sight should be included in the night surveillance plan to insure that surveillance areas overlap and that the entire sector is covered.

APPENDIX A

REFERENCES

<p>AR 345-15 AR 380-5 AR 385-63</p>	<p>Safeguarding Nondefense Information. Safeguarding Defense Information. Regulations for Firing Ammunition for Training, Target Practice and Combat.</p>
<p>FM 20-60 FM 21-5 FM 21-6 FM 21-26 FM 23-65 FM 23-71 FM 23-82</p>	<p>Battlefield Illumination. Military Training Management. Techniques of Military Instruction. Map Reading. Browning Machinegun Caliber .50 HB, M2. Rifle Marksmanship. 106-mm Recoilless Rifle, M40A1.</p>
<p>(0) TM 11-1190-268-15</p>	<p>Organizational, DS, GS, and Depot Maintenance Manual, Including Repair Parts and Special Tool Lists: Starlight Scope, Small, Hand-Held or Individual Weapons Mounted, FSN 1090-688-9954.</p>
<p>(0) TM 11-1090-269-15</p>	<p>Organizational, DS, GS, and Depot Maintenance Manual, Including Repair Parts and Special Tool Lists: Crew-Served Weapon Night Vision Sight, FSN 1090-911-1370.</p>
<p>TM 9-258 TM 9-1900 TM 9-6920-210-14</p>	<p>Elementary Optics and Application to Fire Control Instruments. Ammunition, General. Operator, Organizational, and Field Maintenance Manual: Targets, Target Materials, and Training Course Layouts.</p>
<p>TM 38-750 (0) TC23-11</p>	<p>Army Equipment Record Procedures. Starlight Scope, Small Hand-Held or Individual Weapons Mounted, Model 6060.</p>
<p>TC 5-9</p>	<p>Near Infrared Night Vision and Detection Equipment and Its Application.</p>
<p>TA 23-100-6 (0) ASubjScd 23-13</p>	<p>Ammunition, Rockets, and Missiles for Unit Training, Active Army and Reserve Components. Crew-Served Weapon Night Vision Sight.</p>

APPENDIX B

ADVICE TO INSTRUCTORS

1. Purpose. This appendix is a guide for instructors. Its contents should not limit their initiative and originality.

2. Presentation. *a.* Instruction should be presented using explanation, demonstration, and practical application.

b. Each man's training must be closely supervised to insure a high standard of efficiency and coordination.

3. Training Objective. To provide the soldier with information in sufficient detail to enable him to effectively employ the Sight.

4. Assistant Instructors. Prior to instruction, train selected personnel as demonstrators and assistant instructors. Assistant instructors must be able to correct errors and answer questions that arise during the training. To give the students a clear picture of the work under discussion, insure that the demonstrators are trained and thoroughly rehearsed so that demonstrations are correct in every detail.

5. General Training Notes. *a.* The time required to train a Crew-Served Weapon Night Vision Sight operator with the 106-mm rifle, or the caliber .50 machinegun, is 8 hours. These courses may be increased or decreased depending on training facilities and availability of training time. Training in tactics and technique of employment should be covered during unit training.

b. Although the importance of mechanical and other phases of training should not be de-empha-

sized, the importance of experience gained from range firing exercises during the hours of darkness cannot be overemphasized.

c. Training aids for instruction may be constructed using the photographs and diagrams contained within this training circular as a guide. The training aids should be available in sufficient time to assure that all assistant instructors are thoroughly familiar with them.

d. During classroom presentations, the class may be divided into small groups under the direct supervision of an assistant instructor. The size of the groups will be dependent on the availability of Crew-Served Weapon Night Vision Sights.

e. During daylight instruction, the boresight cover must be positioned over the objective lens to prevent damage to the image intensifier tubes.

6. Conduct of Training. ASubjScd 2-13 should be used as a guide in preparing lesson plans and scheduling periods of instruction with the Crew-Served Weapon Night Vision Sight. The schedule of instruction and scope of training may be limited by the amount of time available, the duties of personnel to be trained, and the equipment available.

7. Security. Since the Crew-Served Weapon Night Vision Sight is a restricted device, adequate physical security measures in accordance with applicable Department of Defense and military directives will be instituted during all operations with the Sight.

INDEX

	Paragraph	Page		Paragraph	Page
Ammunition tables.....	51-54	39	Firing tables:		
Assembly.....	10	5	Known distance.....	51	39
Battery.....	5	4	Stationary target.....	51	39
Boresighting procedures:			10-meter firing.....	53	42
Daylight.....	26	17	Transition range.....	53	42
Night.....	27	18	Functioning of scope.....	16	10
Carrying case.....	4, 5, 7	1, 4, 5	Installation of battery.....	20	13
Controls:			Installation on machinegun.....	18	11
Azimuth adjustment screw.....	12	7	Installation on recoilless rifle.....	19	11
Boresight assembly lock knob.....	12	7	Low temperature adapter.....	17	11
Cant adjustment knob.....	12	7	Maintenance:		
Cant level view port.....	12	7	Daily procedures.....	30	19
Elevation adjustment screw.....	12	7	Materials.....	29	19
Eyepiece focus ring.....	12	7	Troubleshooting.....	31-35	20
Objective lens focus knob.....	12	7	Marksmanship training:		
Objective lens locknut.....	12	7	Purpose.....	45	28
Reticle intensity knob.....	12	7	With machinegun.....	46	28
Rotary control switch.....	12	7	With recoilless rifle.....	47	31
Data, general.....	5	4	Offensive operations.....	58	47
Defensive operations.....	59	47	Performance.....	5	4
Description.....	4	1	Power supply.....	16	10
Destruction to prevent enemy use.....	36	21	Proficiency course.....	55	45
Disassembly.....	9	5	Range determination:		
Employment, factors affecting:			By eye.....	40	22
Atmospheric conditions.....	57	46	By fire.....	41	22
Defensive operations.....	59	47	Map distance.....	39	22
Light.....	57	46	Range firing procedures.....	48, 49	33
Limitations.....	60	47	Range firing tables.....	51-54	39
Offensive operations.....	58	47	Reticle pattern.....	14	7
Positions, selection of.....	61	47	Right angle eyepiece.....	17	11
Terrain.....	57	46	Safety precautions.....	48, 49	33
Fire control:			Scope operation:		
Adjustment of fire.....	43	22	Under normal conditions.....	22	14
Burst-on-target method.....	43	22	Under unusual conditions.....	23	15
Observation-of-tracer method.....	43	22	Sight.....	4, 5	1, 4
			Weapons displacement.....	24	16

By Order of the Secretary of the Army:

Official:

KENNETH G. WICKHAM,
Major General, United States Army,
The Adjutant General.

HAROLD K. JOHNSON,
General, United States Army,
Chief of Staff.

Distribution:

To be distributed in accordance with DA Form 12-11 requirements for Browning Machinegun Cal .50, HB, M2 and 106 MM Recoilless Rifle, M40A1.